

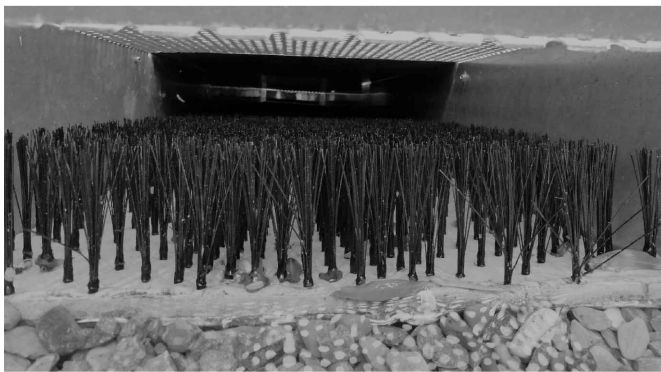

LIFEEL

LIFE19 NAT/IT/000851

Urgent measures in the Eastern Mediterranean for the long term conservation of endangered population of European eel (*Anguilla anguilla*)



ACTION A3 Design of eel specific fish passes to reopen over 1,000 km of habitat for upstream migration of elvers

EEL PASS ON NESTOS RIVER AT TOXOTES DAM



<i>Revision date:</i>	<i>Revision index:</i>	<i>Version:</i>
April 2022	00	Technical specifications

Title of the document:
Technical specification

<i>Ns. Rif.</i>	<i>Date</i>	<i>Scala</i>	<i>Paper size</i>	<i>Document n°</i>
20S30	April 2022		A4	

TECHNICAL DIRECTOR:
Ing. Massimo Sartorelli

DESIGNER:
Ing. Beniamino Barenghi

PARTNER FOR TOXOTES DAM DESIGN:



Signature:



Address: Via Repubblica 1 - 21020 - Varano Borghi (VA)
Tel: +39 0332.961097
Mail to: info@graia.eu - graia@pec.it

Other autors

Verified by
Dott. Ing. Massimo Sartorelli

Approved by
Dott. Ing. Massimo Sartorelli



LIFEEL - LIFE19NAT/IT/000851

URGENT MEASURES IN THE EASTERN MEDITERRANEAN FOR THE LONG
TERM CONSERVATION OF ENDANGERED POPULATION OF EUROPEAN EEL
(*ANGUILLA ANGUILLA*)



ACTION A3: DESIGN OF EEL SPECIFIC FISH PASSES TO REOPEN OVER 1,000 KM
OF HABITAT FOR UPSTREAM MIGRATION OF ELVERS

TABLE OF CONTENTS

FOREWORD	2
1 EEL PASS FEATURES	3
1.1 PART 1 – CONNECTION WITH DOWNSTREAM RIVER	4
1.2 PART 2 – HIGH SLOPE STEEL CHANNEL ON THE SLOPING WALL REST POOL AND.....	6
1.3 PART 3 – LOW SLOPE STEEL CHANNEL AT THE SIDE OF THE WALL	9
1.4 PART 4 – HIGH SLOPE STEEL CHANNEL CLOSED TO MONITORING CABIN	11
1.5 MONITORING CABIN AND CAPTURE POOL.....	13
1.6 RELEASE PIPE AND CHANNEL	16
2 COMPLEMENTARY WORKS	18
2.1 ELECTRICAL CONNECTION	18
2.2 NOTICEBOARDS	19
2.2.1 <i>Eel pass panel</i>	19
2.2.2 <i>Project noticeboard</i>	19
3 PRICES DETAIL	20
4 ECONOMICAL SUMMARY	26

ANNEXES

ANNEX 1	GENERAL PLAN AND PROFILE	SCALE 1 :250
ANNEX 2	PARTS 1, 2, 3 - TECHNICAL DESIGN	SCALE 1:25 – 1:10
ANNEX 3	PART 4 AND MONITORING CABIN - TECHNICAL DESIGN	SCALE 1:25 – 1:10



LIFEEL - LIFE19NAT/IT/000851

URGENT MEASURES IN THE EASTERN MEDITERRANEAN FOR THE LONG
TERM CONSERVATION OF ENDANGERED POPULATION OF EUROPEAN EEL
(*ANGUILLA ANGUILLA*)



ACTION A3: DESIGN OF EEL SPECIFIC FISH PASSES TO REOPEN OVER 1,000 KM
OF HABITAT FOR UPSTREAM MIGRATION OF ELVERS

FOREWORD

The planning of conservation interventions, described in this paper, is part of Action A.3 of the **Project "LIFEEL" LIFE19NAT/IT/000851**, "*Urgent measures in eastern Mediterranean for the long term conservation on endangered European Eel*", co-financed by the European Union, whose lead partner is Regione Lombardia, with the partnership of Regione Emilia-Romagna, Parco Delta del Po Veneto, Parco Delta del Po Emiliano, Parco Lombardo della Valle del Ticino, Universities of Bologna and Ferrara, Demeter and the private consultancy Graia S.r.l.

The project **Action A3** (*Design of eel specific fish passes to reopen over 1,000 km of habitat for free upstream migration of elvers*) provides for the **design of seven devices for the ascent of eels**, six in the low Po River basin and one in Greece, on the Nestos River at about 30 km upstream of its mouth in the Aegean Sea. Action A3 is preparatory to action C3 (by which the devices will be built), and it foresees that Graia S.r.l. will take up the planning of these structures, with the scientific support of Università di Ferrara and the Fisheries Research Institute (F.R.I) of Hellenic Agricultural Organization "Demeter".

In December 2021 Graia s.r.l. submitted to the Fisheries Research Institute (F.R.I) the project for the construction of the Eel pass at the Toxotes dam (on Nestos River in Greece). The project included a description of the objectives of the LIFE project in relation to the intervention, a general overview of the intervention area, a description of the current state of the places, a description of the fish pass, an economical summary of the intervention costs and a design of the fish pass. Then submitted this technical report to the Regional Authorities for the authorization procedure.

At the end of February 2022 the **General management of development, environmental program & infrastructure - Management of technical** works of the Region of Eastern Macedonia & Thrace released the Authorization for the installation of a proposed fishpassage at Toxotes Dam, in the context of the European Program «Urgent measures in the Eastern Mediterranean for the long — term conservation of endangered European eel — LIFEEL».

According to timetable of the Project "LIFEEL" LIFE19NAT/IT/000851, the "the Fisheries Research Institute (F.R.I) of Hellenic Agricultural Organization "Demeter" has to contract the construction of the Eel pass on Nestos river to a qualified firm.

This paper and its annexes drawings are the technical specification necessary to stipulate the contract between F.R.I and the firm.



LIFEEL - LIFE19NAT/IT/000851

URGENT MEASURES IN THE EASTERN MEDITERRANEAN FOR THE LONG
TERM CONSERVATION OF ENDANGERED POPULATION OF EUROPEAN EEL
(*ANGUILLA ANGUILLA*)



ACTION A3: DESIGN OF EEL SPECIFIC FISH PASSES TO REOPEN OVER 1,000 KM
OF HABITAT FOR UPSTREAM MIGRATION OF ELVERS

1 EEL PASS FEATURES

The eel pass is formed by three parts and two rest pool. At the top of the last part is located the monitoring cabin, where elvers can be stored for a short time or filmed by monitoring camera. From capture pool located inside the monitoring cabin elvers are released in the upstream river through a steel pipe. In the following pages there is a short description of each part of the designed system.

In Chapter 3 is detailed the cost related to the construction of the eel pass (bill of quantities).

In Chapter 4 is summarized the cost of the intervention, divided into supplies and manpower.

The eel pass will be built on the concrete wall between the discharge gate on the right bank of the river and the central body of the dam.

A general drawn of the fish-pass is shown in Annex 1.

TOXOTES DAM – VIEW FROM UPSTREAM, RIGHT BANK



TOXOTES DAM – VIEW FROM DOWNSTREAM, RIGHT BANK





1.1 PART 1 – CONNECTION WITH DOWNSTREAM RIVER

This part consists in an open flow channel formed by a double steel profile (used as lateral permanent formwork) and high roughness concrete (with cobblestone and gravel inside).

The steel profiles are “L” shape and 100 x 100 x 10 mm size. The profiles are connected to the concrete wall through bolt anchors M16 x 140. An iron mesh 10 x 10 cm, $\Phi 8$ mm is included in the concrete layer. The concrete layer is shaped in order to form a flat, high roughness channel.

The open water flow discharged from the water call pipe flows outside the upper steel profile.

Geometrical features:

- Length: 25 m
- Width: 0.5 ÷ 0.6 m
- Slope: 7°

Part 1 construction features are shown in Annex 2.

STEEL BARS FIXING IN PART 1

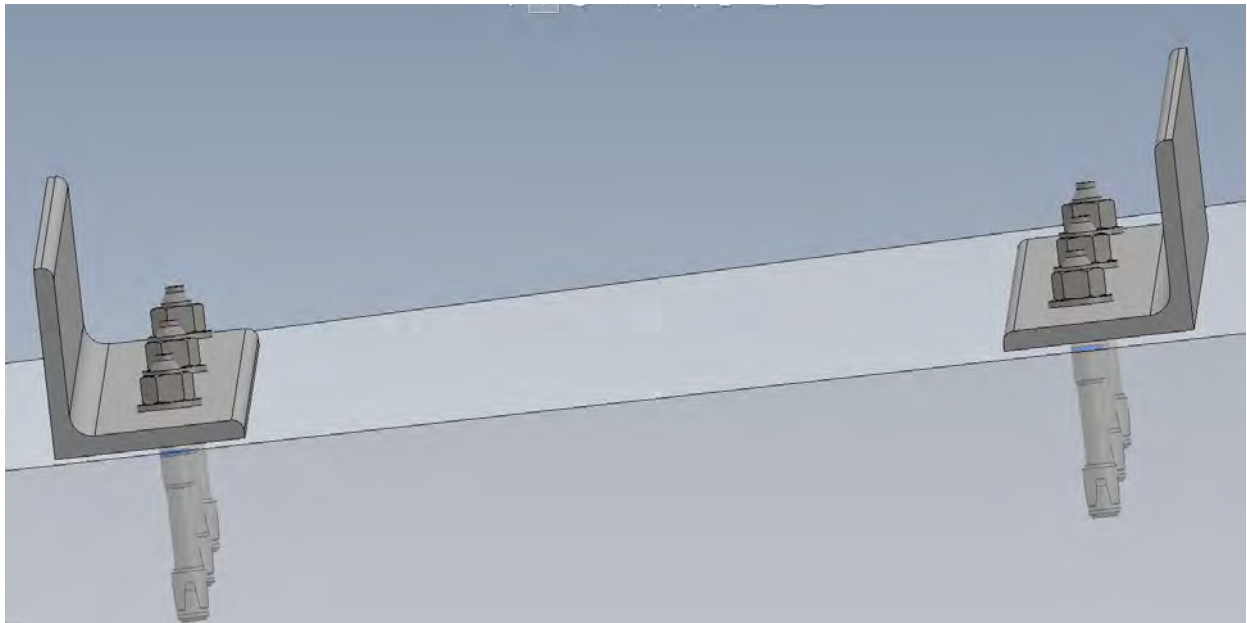



LIFEEL - LIFE19NAT/IT/000851

URGENT MEASURES IN THE EASTERN MEDITERRANEAN FOR THE LONG TERM CONSERVATION OF ENDANGERED POPULATION OF EUROPEAN EEL (*ANGUILLA ANGUILLA*)



ACTION A3: DESIGN OF EEL SPECIFIC FISH PASSES TO REOPEN OVER 1,000 KM OF HABITAT FOR UPSTREAM MIGRATION OF ELVERS

THE WALL BEHIND THE DAM WHERE PART 1 WILL BE BUILT



STEEL BARS FIXING IN PART 1

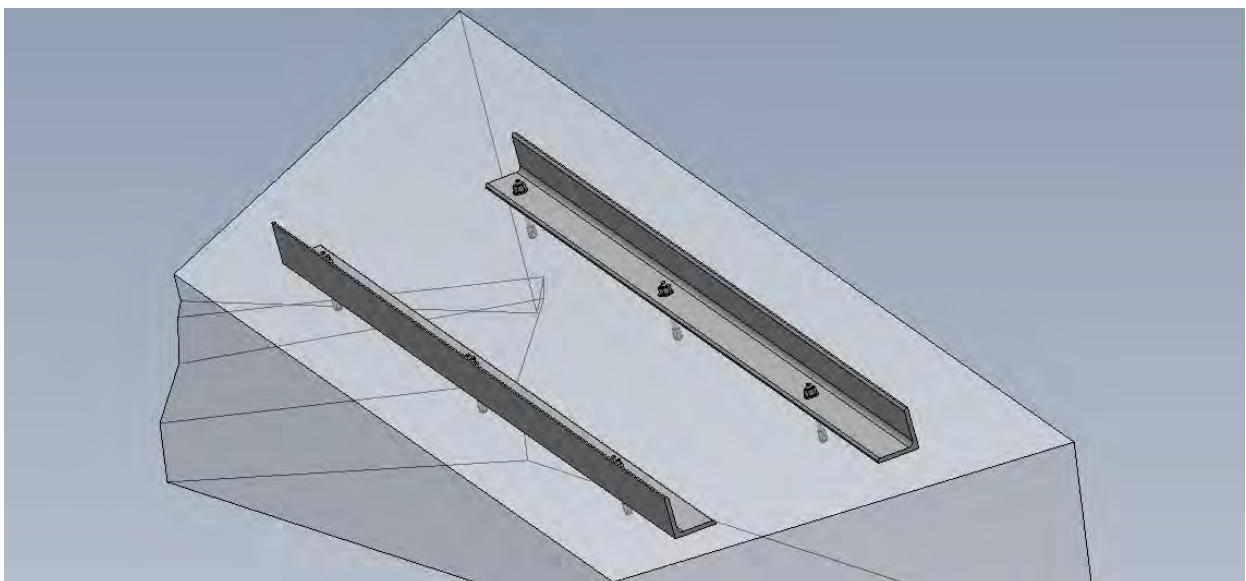



1.2 PART 2 – HIGH SLOPE STEEL CHANNEL ON THE SLOPING WALL REST POOL AND

This part consists in galvanized steel channel set on the sloping wall between the main river and the lateral discharge channel. The channel consists in 12 standard parts, long 150 cm each. The parts are funnel coupling: the terminal section of each part is tighter than the main body, in order to enter the previous part.

Each part is a 400 x 200 mm channel, thickness 3 mm, with a “L” shape steel profile 50 x 50 x 5 mm, welded on each side.

The channels are connected to the concrete wall through bolt anchors M8 x 75 set on the lateral “L” profile.

A Bristle board eel substrate is set inside the channel. Bristle board substrate is an artificial substrate made by:

- a 9-10 mm thick black polypropylene support mat;
- 1 mm diameter bristles, made of green or black polyester, grouped in bunches of a number such as to fill holes of 5 mm;
- the length of the bristles must be 70 to 100 millimeters; the spacing (vertical and horizontal) between the holes must be 20 mm in the central corridor and 30 mm on the side bands,
- the offset between parallel lines must be 10 mm in the central part and 20 mm on the sides.

A galvanized steel cover is hinged on each part of the channel.

The water call pipe is fixed beside the channel.

Geometrical features:

- Length: 18 m
- Width: 0.4 m
- Slope: 27°

The rest pool is set on the upper terminal of the channel. It consists in a special part (**SP 1** in Annex 2) that is formed by a short channel to be connected to the main channel of PART 2 and by a rectangular pool 1205 x 600 mm large. The pool is 230 mm high and it is fixed on the sloping wall through special frames made by “L” shape steel profile 50 x 50 x 5 mm. The upper long side of the pool has a 400 mm large opening in order to be connected to PART 3. The rest pool is filled with a 10 cm layer of natural river gravel.

Part 2 construction features are shown in Annex 2



LIFEEL - LIFE19NAT/IT/000851

URGENT MEASURES IN THE EASTERN MEDITERRANEAN FOR THE LONG TERM CONSERVATION OF ENDANGERED POPULATION OF EUROPEAN EEL (*ANGUILLA ANGUILLA*)



ACTION A3: DESIGN OF EEL SPECIFIC FISH PASSES TO REOPEN OVER 1,000 KM OF HABITAT FOR UPSTREAM MIGRATION OF ELVERS

THE WALL BEHIND THE DAM WHERE PART 2 WILL BE BUILT



BRISTLE BOARD SUBSTRATE

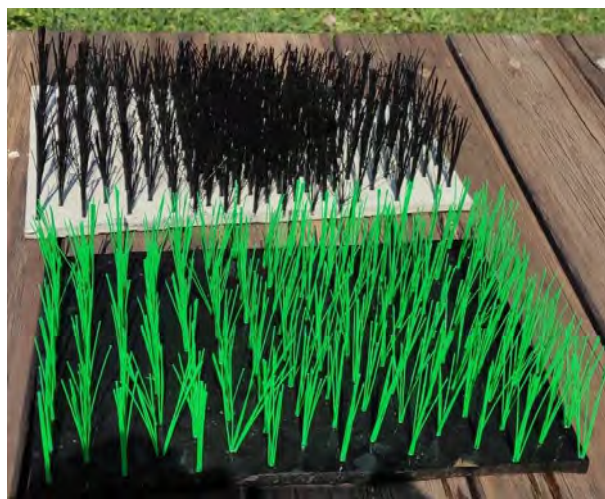



LIFEEL - LIFE19NAT/IT/000851

URGENT MEASURES IN THE EASTERN MEDITERRANEAN FOR THE LONG TERM CONSERVATION OF ENDANGERED POPULATION OF EUROPEAN EEL (*ANGUILLA ANGUILLA*)



ACTION A3: DESIGN OF EEL SPECIFIC FISH PASSES TO REOPEN OVER 1,000 KM OF HABITAT FOR UPSTREAM MIGRATION OF ELVERS

REST POOL FILLED WITH GRAVEL (LEFT) AND STEEL SHEET CHANNEL (RIGHT)

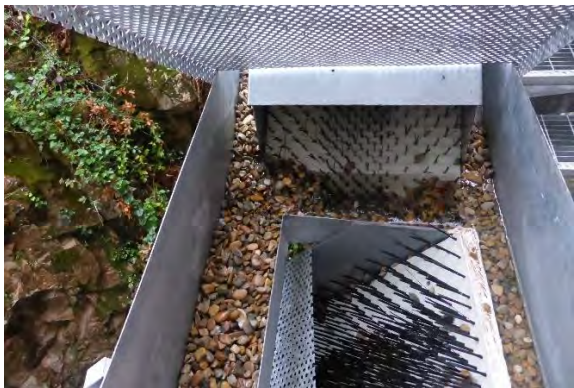

PART 2 - CHANNEL AND REST POOL

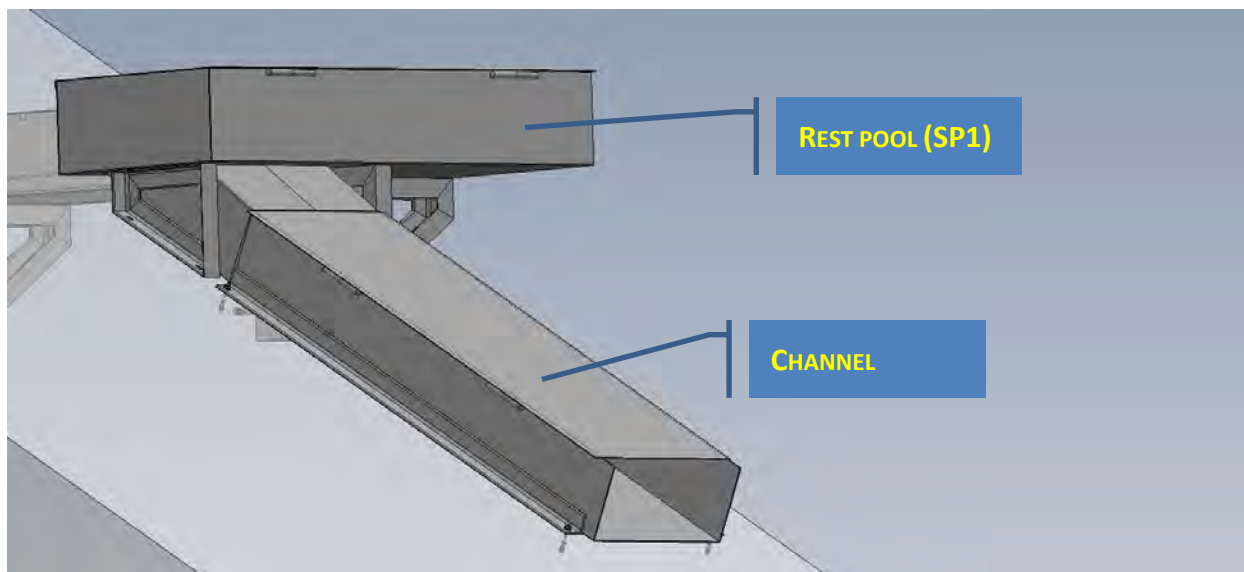



1.3 PART 3 – LOW SLOPE STEEL CHANNEL AT THE SIDE OF THE WALL

This part consists in galvanized steel channel set on steel brackets. The channel, the cover and the bristle board substrate are the same used for PART 2.

Brackets are built with UPN100 steel bars, they spaced 1500 mm and they are connected to the vertical wall through 3 bolt anchors M16 x 140 for each bracket.

Each Bracket matches the junction of the parts of the channel. Each part of the channel is fixed to the brackets by TE ISO4017 – M8x30-8.8 screws and a ISO4032-M8-8 nuts.

The water call pipe is fixed on the brackets, beside the channel, or inside de “D” shape of the brackets.

Geometrical features:

- Length: 30,5 m
- Width: 0.4 m
- Slope: $\approx 1^\circ$

Part 3 construction features are shown in Annex 2.

The wall behind the dam where PART 3 will be built





LIFEEL - LIFE19NAT/IT/000851

URGENT MEASURES IN THE EASTERN MEDITERRANEAN FOR THE LONG
TERM CONSERVATION OF ENDANGERED POPULATION OF EUROPEAN EEL
(*ANGUILLA ANGUILLA*)



ACTION A3: DESIGN OF EEL SPECIFIC FISH PASSES TO REOPEN OVER 1,000 KM
OF HABITAT FOR UPSTREAM MIGRATION OF ELVERS

PART 2 AND PART 3- TOP VIEW

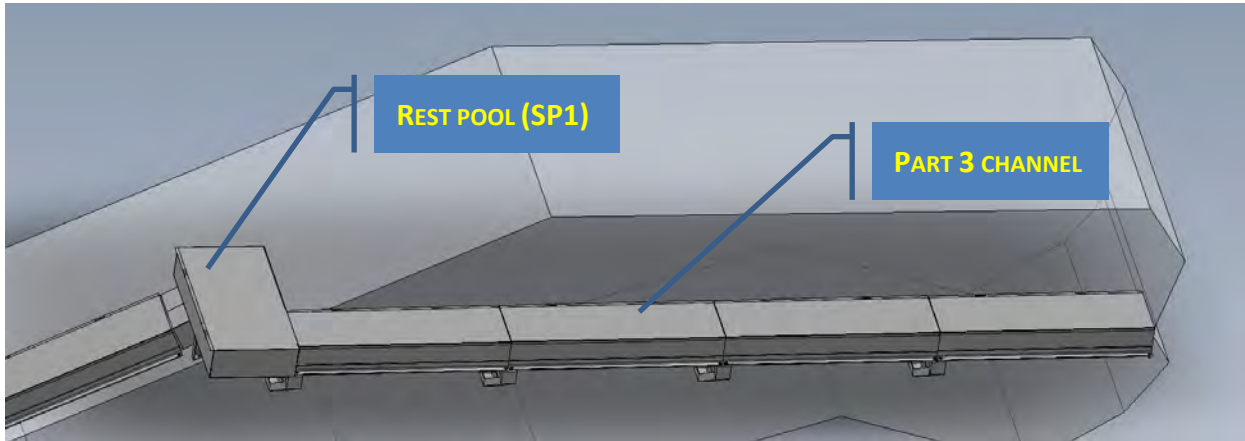

PART 2 AND PART 3- BOTTOM VIEW

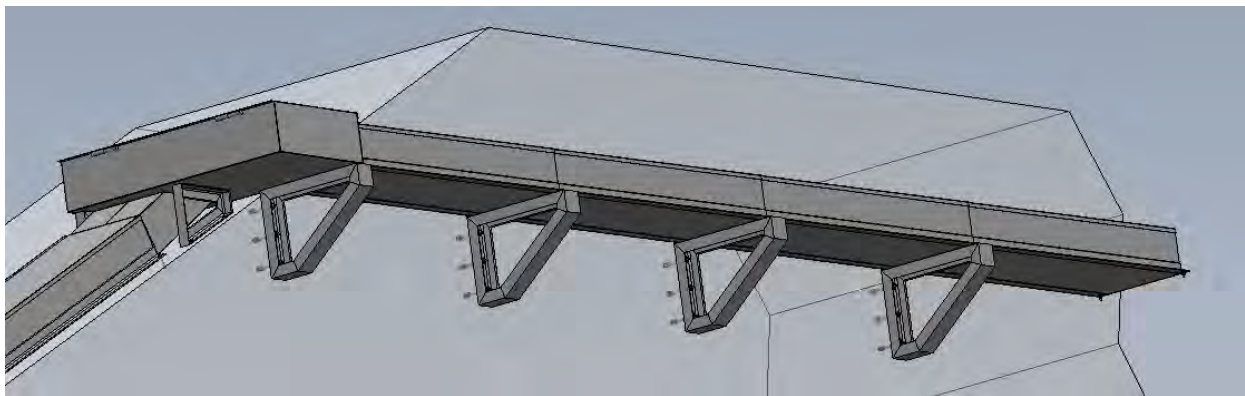

PART 3- BRACKETS AND CHANNEL FIXING

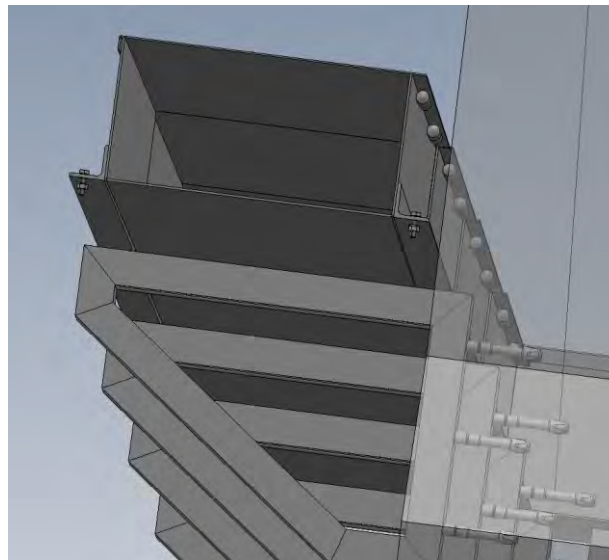
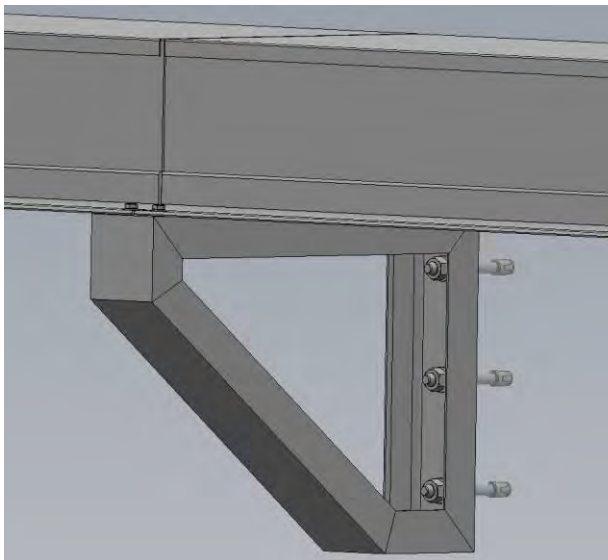



1.4 PART 4 – HIGH SLOPE STEEL CHANNEL CLOSED TO MONITORING CABIN

PART 4 is the upstream progression of PART 3. It consists in 2 short high-slope channels and a rest pool in the middle.

The **downstream channel** is the progression of PART 3: it is 1500 mm long and it is fixed to the concrete wall through the same brackets used for PART 3. The slope is 37°; slope and length must be verified during the tracing and the construction of the fish-pass. The downer bracket is shared with PART 3, the upper one should be modified in order to have the upper face 37° sloped.

The channel, the cover and the bristle board substrate are the same used for PART 2 and PART 3.

The **rest pool** is set on the upper face of the concrete wall where monitoring cabin is also set. It is a special part (Special part **SP 2** in Annex 3) that is formed by a short channel to be connected to the downstream high-slope channel and by a rectangular pool 1505 x 600 mm large. The pool is 230 mm high and it is fixed to the flat concrete wall through bolt anchors M8 x 75 set on the lateral “L” profile. The rest pool is filled with a 10 cm layer of natural river gravel.

The **upstream channel** connects the rest pool to the monitoring cabin. It is 1300 mm long and it doesn't need any bracket to be fixed to the wall. The slope is 37° and it must be verified in the workshop while building the monitoring cabin. The channel, the cover and the bristle board substrate are the same used for PART 2 and PART 3.

The water call pipe is fixed on the brackets, beside the channel, and it enters the monitoring cabin beside the rest pool, on the flat concrete wall.

PART 4 construction features are shown in Annex 3.

PART 4 POSITION

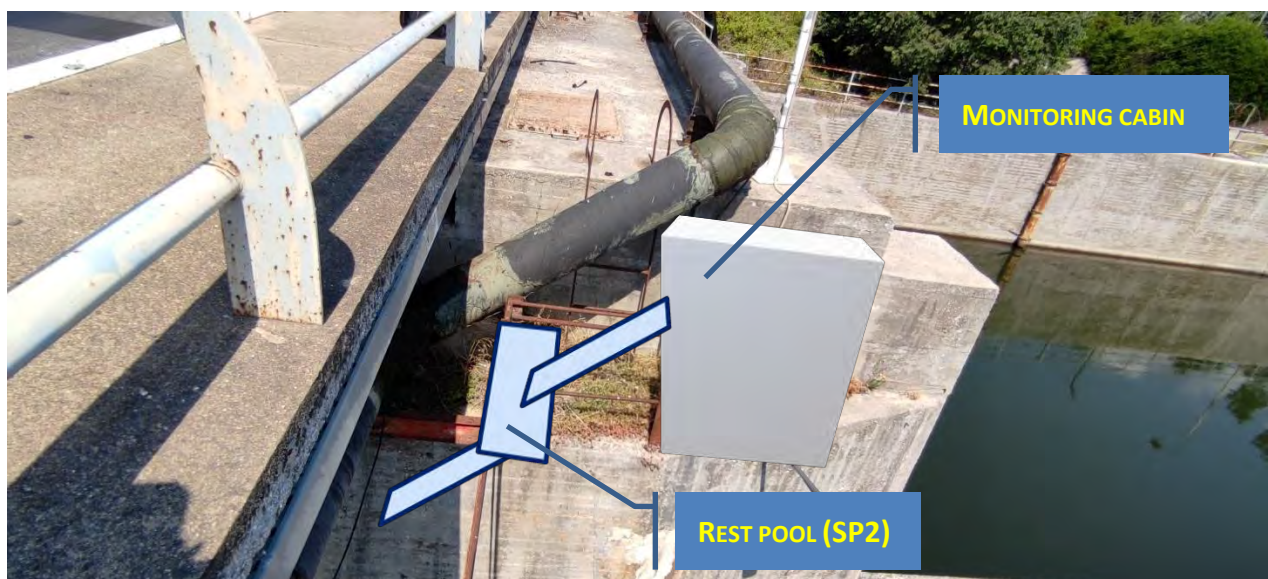



LIFEEL - LIFE19NAT/IT/000851

URGENT MEASURES IN THE EASTERN MEDITERRANEAN FOR THE LONG TERM CONSERVATION OF ENDANGERED POPULATION OF EUROPEAN EEL (*ANGUILLA ANGUILLA*)



ACTION A3: DESIGN OF EEL SPECIFIC FISH PASSES TO REOPEN OVER 1,000 KM OF HABITAT FOR UPSTREAM MIGRATION OF ELVERS

REST POOL FILLED WITH GRAVEL (LEFT) AND CHANNEL NEXT TO MONITORING CABIN



PART 4 – FRONTAL VIEW

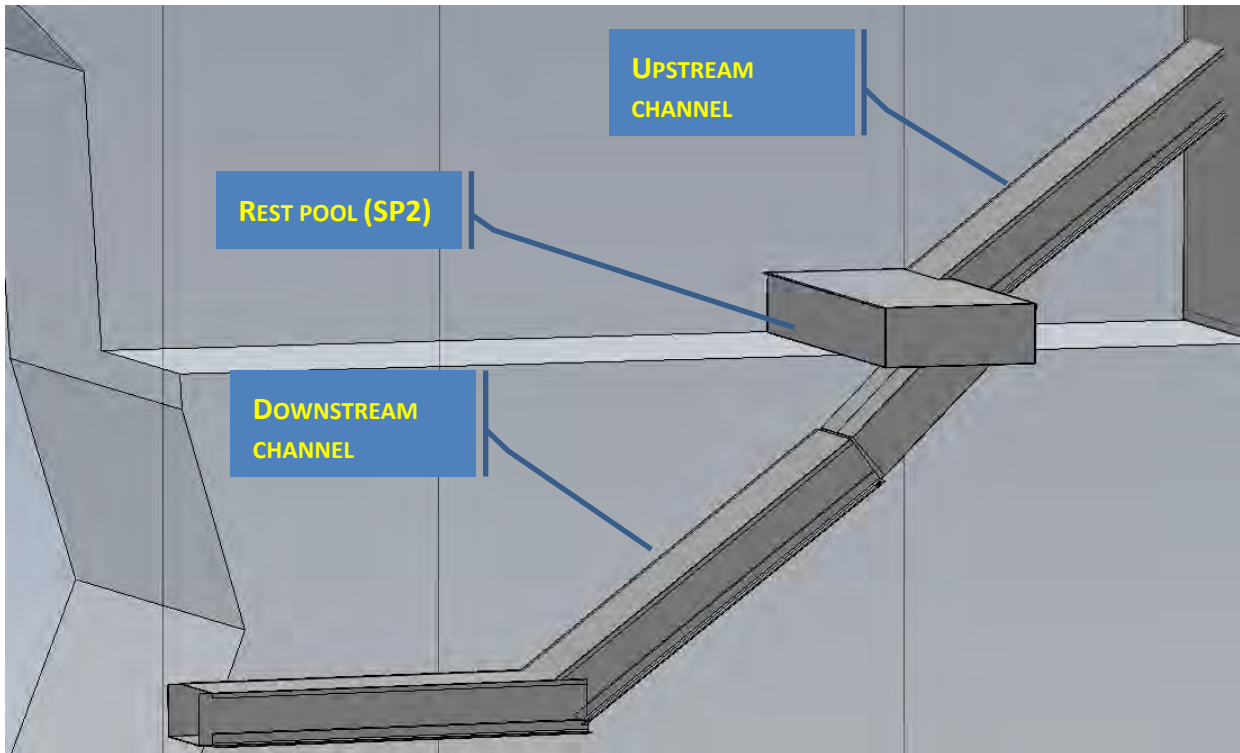



1.5 MONITORING CABIN AND CAPTURE POOL

The **monitoring cabin** (Special part **SP3** in Annex 3) is a steel structure, with a locking door, set on an existing shell beside the road, on the intake side of the bridge. The front side is formed by a double door that covers the entire side of the cabin. The following equipment is placed inside the cabin:

1. Electrical cabinet and pump magnetothermal switch
2. Hydraulic and distribution system
3. Distribution system
4. Capture and monitoring pool
5. Shell for remote monitoring system
6. Connection with uprising channel (PART 4)
7. Connection with elvers discharge pipe
8. Connection with water call pipe

Geometrical features:

- Width: 1000 mm
- Height: 1500 mm
- Depth: 600 to 1000 mm

A walkway and a stair to access the monitoring cabin will be built. The walkway (Special part **SP4** in Annex 3) is formed by an electro-welded grating (size 2000 x 800 mm, grate 25 x 76, 25 x 3), supported by two brackets: the brackets and the support frame are built with UPN120 steel bars, and steel bars 80 x 6. Around two sides of the walkway, a 2 meters high protection steel corrugated net is set. On the PART 4 side, instead of the net, the walkway is protected by 1100 mm high hand guard (Special part **SP5** in Annex 3).

A double stair is built to reach the walkway from the upper concrete wall and from the bridge. A steel gate is installed at the top of the stair. The access area and the stair are protected by lateral safety handrail (Special part **SP6** in Annex 3).

Monitoring cabin construction features are shown in Annex 3.



LIFEEL - LIFE19NAT/IT/000851

URGENT MEASURES IN THE EASTERN MEDITERRANEAN FOR THE LONG
TERM CONSERVATION OF ENDANGERED POPULATION OF EUROPEAN EEL
(*ANGUILLA ANGUILLA*)



ACTION A3: DESIGN OF EEL SPECIFIC FISH PASSES TO REOPEN OVER 1,000 KM
OF HABITAT FOR UPSTREAM MIGRATION OF ELVERS

LOCATION OF MONITORING CABLE AND ITS ACCESS WAY

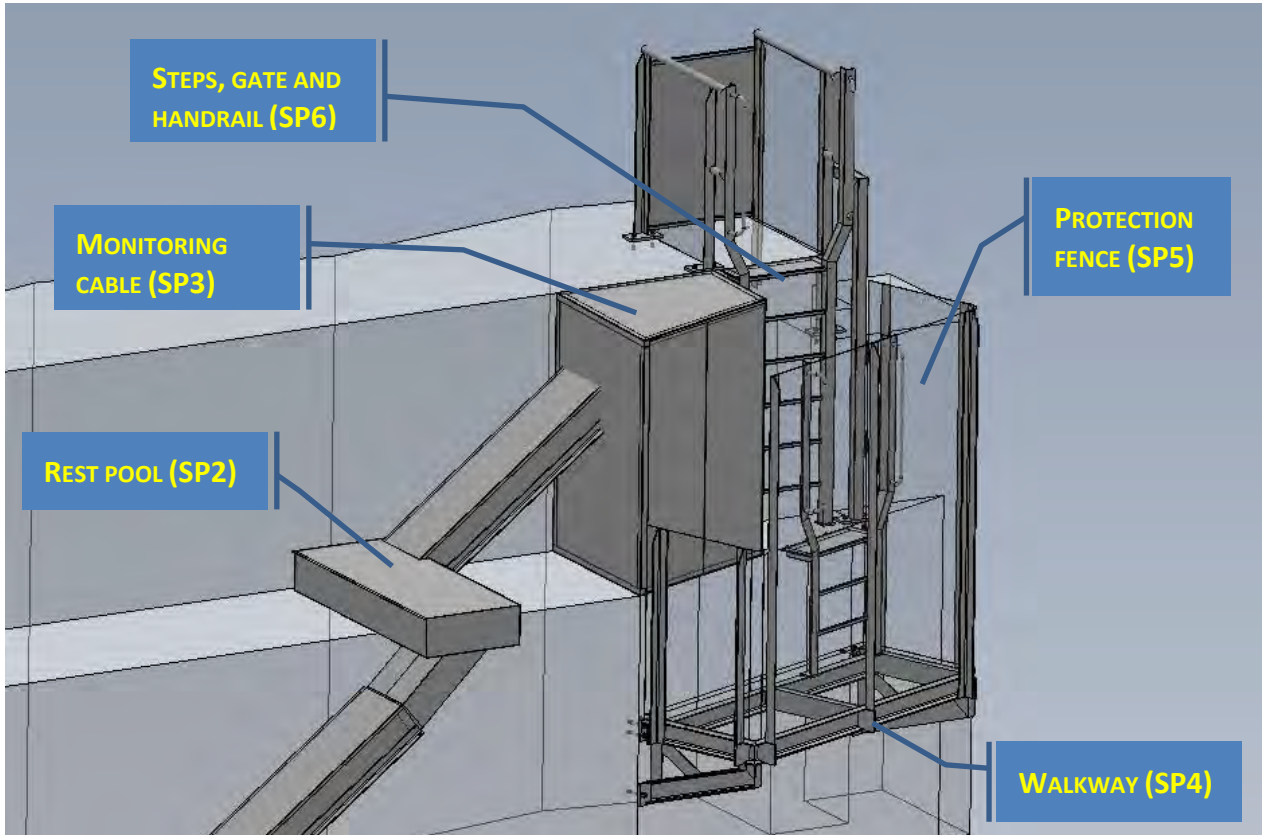



LIFEEL - LIFE19NAT/IT/000851

URGENT MEASURES IN THE EASTERN MEDITERRANEAN FOR THE LONG TERM CONSERVATION OF ENDANGERED POPULATION OF EUROPEAN EEL (*ANGUILLA ANGUILLA*)



ACTION A3: DESIGN OF EEL SPECIFIC FISH PASSES TO REOPEN OVER 1,000 KM OF HABITAT FOR UPSTREAM MIGRATION OF ELVERS

MONITORING CABLE EQUIPMENT

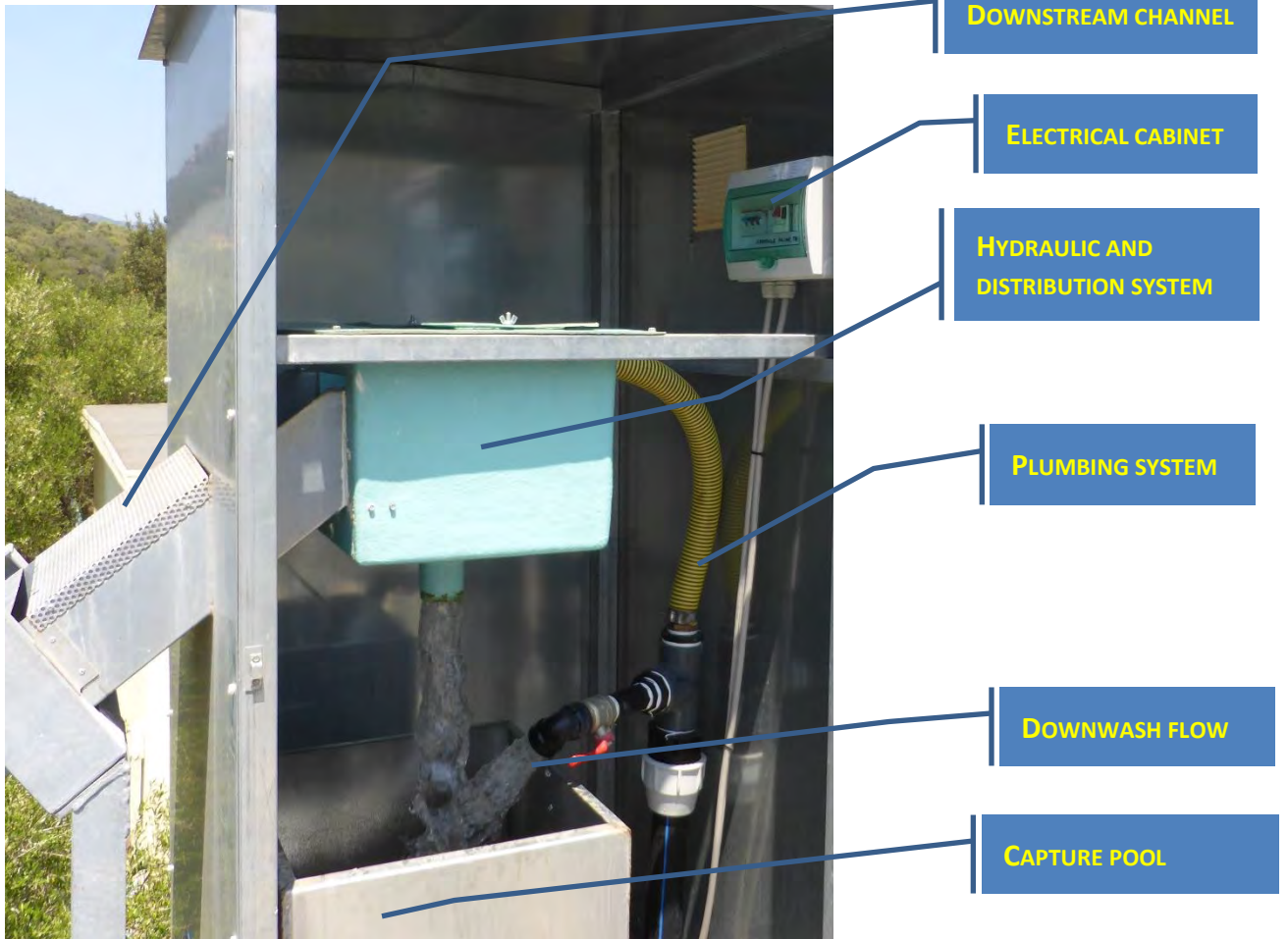

DISTRIBUTION SYSTEM (LEFT) AND CAPTURE POOL (RIGHT)

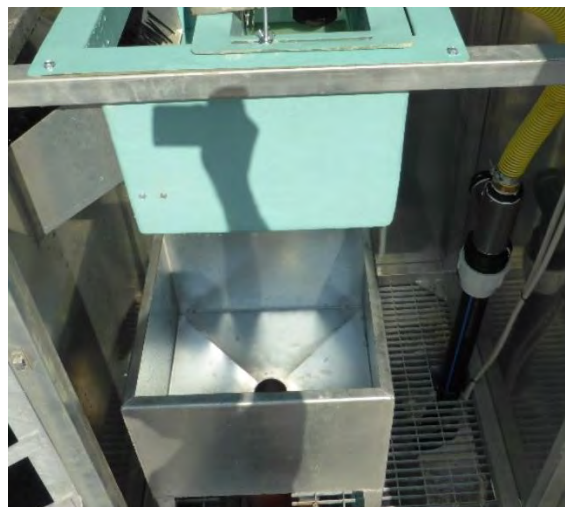



1.6 RELEASE PIPE AND CHANNEL

The **eel release system consists** in a stainless-steel pipe (like the ones used to downwash stormwater from the roofs) connected with the capture pool. The diameter of the pipe is 150 mm and it is 15 meters long.

The supply includes:

- 15 meters of linear pipe, diameter 150 mm
- 3 90° elbows
- 1 45° elbow
- 8 stainless-steel rings to fix the pipe to the concrete wall

The **water supply system** consists in:

- 1 stainless-steel submersible pump (Head: 4-13 m, Flow: 2-5 l/s, single phase, Power 1.1 kW), including arrest float
- 2.5 m of hot dip galvanized steel pipe (Diameter 324 mm, thickness 5 mm), to protect the pump from floating materials carried by the river
- 12 meters of HDPE Pipe, NP 10 bar, External diameter 75 mm, to connect the pump to the plumbing system inside the monitoring cabin
- 52 meters of HDPE Pipe, NP 10 bar, External diameter 63 mm, to use for the water call system to install next to the fish-pass.



LIFEEL - LIFE19NAT/IT/000851

URGENT MEASURES IN THE EASTERN MEDITERRANEAN FOR THE LONG TERM CONSERVATION OF ENDANGERED POPULATION OF EUROPEAN EEL (*ANGUILLA ANGUILLA*)



ACTION A3: DESIGN OF EEL SPECIFIC FISH PASSES TO REOPEN OVER 1,000 KM OF HABITAT FOR UPSTREAM MIGRATION OF ELVERS

EEL RELEASE PIPE



WATER SUPPLY SYSTEM

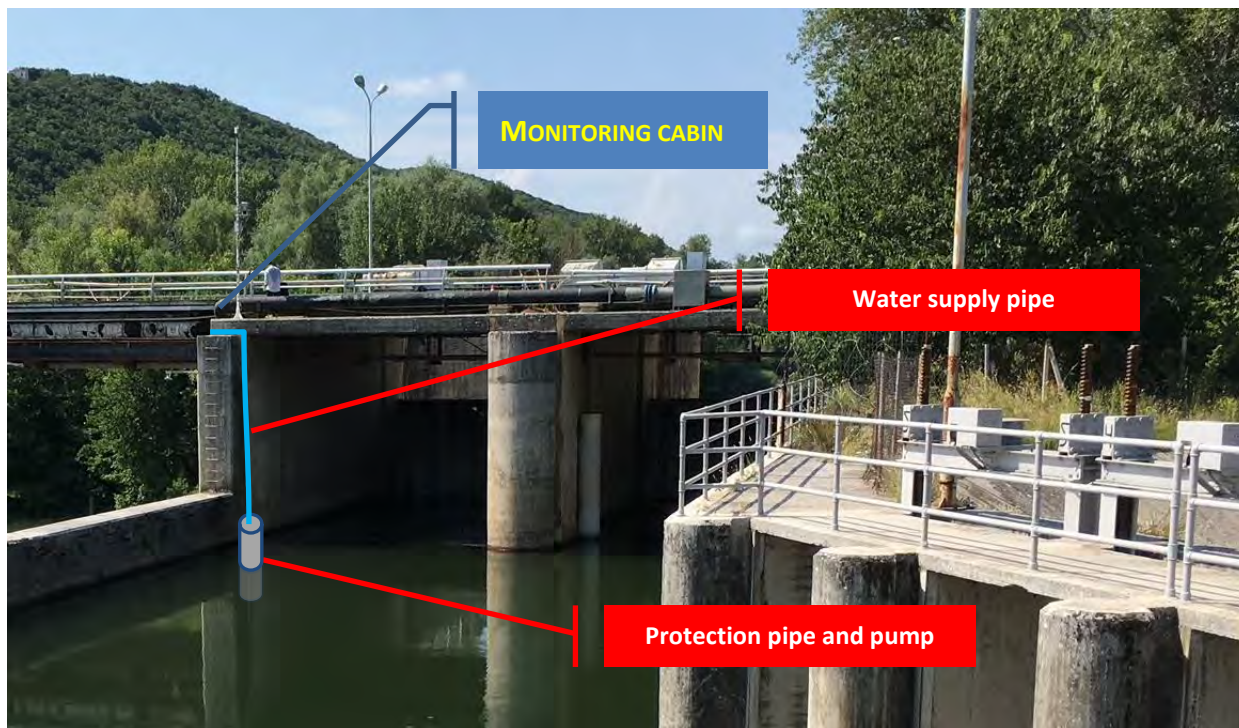



LIFEEL - LIFE19NAT/IT/000851

URGENT MEASURES IN THE EASTERN MEDITERRANEAN FOR THE LONG TERM CONSERVATION OF ENDANGERED POPULATION OF EUROPEAN EEL (*ANGUILLA ANGUILLA*)



ACTION A3: DESIGN OF EEL SPECIFIC FISH PASSES TO REOPEN OVER 1,000 KM OF HABITAT FOR UPSTREAM MIGRATION OF ELVERS

2 COMPLEMENTARY WORKS

2.1 ELECTRICAL CONNECTION

The water supply system of the eel pass needs to be connected to the electrical network.

The way to connect the eel pass to the electrical network is not matter of the project. The easiest way to do it is to connect the eel pass to the water supply plant on the right bank of Nestos River. Otherwise, the eel pass can be connected to the street lighting network.

This topic will be discussed with local authorities before starting the works.





2.2 NOTICEBOARDS

Two permanent noticeboards will be provided and installed by the firm during the construction of the eel-pass. For both of them Graia S.r.l. will take care of the graphic design and will supply the firm with the printing files.

The Noticeboards are the following.

2.2.1 Eel pass panel

- Size: 1000 x 1000 mm
- Support: dibond panel, minimum thickness 3 mm
- Location: outside the protection fence of the monitoring cabin; the panel must be visible from the bridge

2.2.2 Project noticeboard

- Size: 1600 x 800 mm
- Support: dibond panel, minimum thickness 3 mm
- Location: on the wood bulletin provided by the firm; the location of the wood bulletin will be decided during the work together with the local authorities.



3 PRICES DETAIL

	UNITS	NUMBER	LENGTH	WIDTH	HEIGH/WEIGHT	QUANTITY	UNIT COST	TOTAL COST
WORKSITE SETUP								2'030.00 €
Equipment transport, security fences, security signs		1				1.00	750.00 €	350.00 €
Rental of electrical generator, tiller, drill, welding machine, rock climber equipment,	days	30				30.00	25.00 €	750.00 €
Site cleaning and rubbish removal		1				1.00	250.00 €	250.00 €
Eel pass tracking - topographer	hrs	8				8.00	35.00 €	280.00 €
Eel pass tracking - rock climbers workers (2 persons for 1 day)	hrs	16				16.00	25.00 €	400.00 €
PART 1 - DOWNSTREAM CONNECTION								8'480.00 €
Downstream channel - Hot dip galvanized steel bars 100 x 100 x 10 mm	kg	2	25.00		15.10	755.00	7.00 €	5'285.00 €
Downstream channel - Concrete with gravel	kg		25.00	0.50	0.20	2.50	120.00 €	300.00 €
Downstream channel - Electro-welded mesh (10 x 10 cm, F 8 mm)	kg	8	25.00	0.50		100.00	2.50 €	250.00 €
Connection between downstream channel and part 2 - formwork	m ²	2	1.00	1.00		2.00	45.00 €	90.00 €
Connection between downstream channel and part 2 - concrete	m ²		1.00	0.50	0.50	0.25	120.00 €	30.00 €
Connection between downstream channel and part 2 - steel rods	kg				50.00	50.00	2.50 €	125.00 €
Manpower - 3 rock climber workers team (4 days): <i>Transport of materials and equipment from the road to the working site, bars fastening, concrete transport and settling, connection of the steel rods with the existing building)</i>	hrs	12			8.00	96.00	25.00 €	2'400.00 €



LIFEEL - LIFE19NAT/IT/000851

URGENT MEASURES IN THE EASTERN MEDITERRANEAN FOR THE LONG TERM CONSERVATION OF ENDANGERED POPULATION OF EUROPEAN EEL (ANGUILLA ANGUILLA)



ACTION A3: DESIGN OF EEL SPECIFIC FISH PASSES TO REOPEN OVER 1,000 KM OF HABITAT FOR UPSTREAM MIGRATION OF ELVERS

	UNITS	NUMBER	LENGTH	WIDTH	HEIGH/WEIGHT	QUANTITY	UNIT COST	TOTAL COST
PART 2 - HIGH SLOPE STEEL CHANNEL ON THE CONCRETE WALL AND REST POOL								11'368.44 €
Channel - hot dip galvanized steel bars 50 x 50 x 5 mm	kg	2	18.00		3.77	135.72	7.00 €	950.04 €
Channel - hot dip galvanized steel sheet (150 x 40 x 20 cm, thickness 3 mm)	kg		18.00	0.80	23.55	339.12	7.00 €	2'373.84 €
Cover - hot dip galvanized steel sheet (150 x 40 x 2 cm, thickness 2 mm)	kg		18.00	0.45	15.40	124.74	7.00 €	873.18 €
Substrate "Bristle board" 400 mm wide, 20 - 30 mm spacing	m		18.00			18.00	240.00 €	4'320.00 €
Rest pool - hot dip galvanized steel sheet and bar - Special part SP1	kg				64.00	64.00	7.00 €	448.00 €
Rest pool - Gravel supply	m ³		1.00	0.50	0.15	0.08	45.00 €	3.38 €
Manpower - 3 rock climber workers team (4 days): <i>Transport of materials and equipment from the road to the working site, bars fastening, eel board fastening)</i>	hrs	12			8.00	96.00	25.00 €	2'400.00 €
PART 3 - LOW SLOPE STEEL CHANNEL BESIDE THE CONCRETE WALL								22'488.10 €
Steel support (UPN 100)	kg	22	1.71		10.60	397.61	7.00 €	2'783.24 €
Channel - hot dip galvanized steel bars 50 x 50 x 5 mm	kg	2	31.50		3.77	237.51	7.00 €	1'662.57 €
Channel - hot dip galvanized steel sheet (150 x 40 x 20 cm, thickness 3 mm)	kg		31.50	0.80	23.55	593.46	7.00 €	4'154.22 €
Cover - hot dip galvanized steel sheet (150 x 40 x 2 cm, thickness 2 mm)	kg		31.50	0.45	15.40	218.30	7.00 €	1'528.07 €
Substrate "Bristle board" 400 mm wide, 20 - 30 mm spacing	m		31.50			31.50	240.00 €	7'560.00 €
Manpower - 3 rock climber workers team (8 days): <i>Transport of materials and equipment from the road to the working site, bars fastening, eel board fastening)</i>	hrs	24			8.00	192.00	25.00 €	4'800.00 €



LIFEEL - LIFE19NAT/IT/000851

URGENT MEASURES IN THE EASTERN MEDITERRANEAN FOR THE LONG TERM CONSERVATION OF ENDANGERED POPULATION OF EUROPEAN EEL (ANGUILLA ANGUILLA)



ACTION A3: DESIGN OF EEL SPECIFIC FISH PASSES TO REOPEN OVER 1,000 KM OF HABITAT FOR UPSTREAM MIGRATION OF ELVERS

	UNITS	NUMBER	LENGTH	WIDTH	HEIGH/WEIGHT	QUANTITY	UNIT COST	TOTAL COST
PART 4 - MONITORING CABIN CONNECTION								2'547.46 €
Steel support	kg	1	1.71		10.60	18.07	7.00 €	126.51 €
Channel - hot dip galvanized steel bars 50 x 50 x 5 mm	kg	2	2.80		3.77	21.11	7.00 €	147.78 €
Channel - hot dip galvanized steel sheet (150 x 40 x 20 cm, thickness 3 mm)	kg		2.80	0.80	23.55	52.75	7.00 €	369.26 €
Cover - hot dip galvanized steel sheet (150 x 40 x 2 cm, thickness 2 mm)	kg		2.80	0.45	15.40	19.40	7.00 €	135.83 €
Substrate "Bristle board" 400 mm wide, 20 - 30 mm spacing	m		2.80			2.80	240.00 €	672.00 €
Rest pool - hot dip galvanized steel sheet and bar - Special part SP2	kg				70.00	70.00	7.00 €	490.00 €
Rest pool - Gravel supply	m ³		1.50	0.60	0.15	0.14	45.00 €	6.08 €
Manpower - 3 rock climber workers team (1 day): <i>Transport of materials and equipment from the road to the working site, bars fastening, eel board fastening)</i>	hrs	3			8.00	24.00	25.00 €	600.00 €

MONITORING CABIN AND CAPTURE POOL								9'314.30 €
Cabin - hot dip galvanized steel bar and sheet - Special part SP3	kg				200.00	200.00	7.00 €	1'400.00 €
Walkway - hot dip galvanized steel bar and grating - Special part SP4	kg				150.00	150.00	7.00 €	1'050.00 €
Fence and handrail around the walkway - Special part SP5	kg				200.00	50.00	7.00 €	350.00 €
Double stair to access the walkway (steps, guards and gate) - Special part SP6	kg				200.00	98.90	7.00 €	692.30 €
Prefabricated module "Irrigation and capture system". Supply and transport of irrigation and trapping systems to be placed inside the monitoring cabin. The price includes the supply of: - 2 prefabricated fiberglass tanks: water collection and delivery tank (50 x 20 x 20 cm) and water distribution tank (50 x 40 x 40 cm) -1 hot dip galvanized eel collection / evacuation tank (80 x 80 x 30 cm);	unit	1				1.00	2'950.00 €	2'950.00 €





LIFEEL - LIFE19NAT/IT/000851

URGENT MEASURES IN THE EASTERN MEDITERRANEAN FOR THE LONG TERM CONSERVATION OF ENDANGERED POPULATION OF EUROPEAN EEL (ANGUILLA ANGUILLA)



ACTION A3: DESIGN OF EEL SPECIFIC FISH PASSES TO REOPEN OVER 1,000 KM OF HABITAT FOR UPSTREAM MIGRATION OF ELVERS

	UNITS	NUMBER	LENGTH	WIDTH	HEIGH/WEIGHT	QUANTITY	UNIT COST	TOTAL COST
<p>- 1 partially perforated lid for the eel collection tank; - 1 thermometer; - hydraulic fittings and fixing brackets to complete the works inside the monitoring cabin. All the fiberglass tanks (fiberglass and thermosetting resin based on polyester) must be equipped with reinforced upper edges to facilitate fixing and resting on the brackets placed inside the cabin. The eel collection / evacuation tank, on the other hand, must be equipped with a bottom drain, an overflow and a stainless-steel filter grid. The price includes the supply and transport.</p>								
Electrical cabinet, small parts for electrical system	unit	1				1.00	750.00 €	750.00 €
Fittings, valves, short pipes for plumbing system	unit	1				1.00	450.00 €	450.00 €
Manpower - 3 rock climber workers team (2 day): <i>Transport of materials and equipment from the road to the working site, bars fastening, eel board fastening)</i>	hrs	6			8.00	48.00	32.00 €	1'536.00 €
Manpower - metal worker (2 workers, 2 days)	hrs	4			8.00	32.00	24.00 €	768.00 €
Manpower - electrician worker (2 days)	hrs	2			8.00	16.00	24.00 €	384.00 €
Manpower - plumber worker (2 days)	hrs	2			8.00	16.00	24.00 €	384.00 €



LIFEEL - LIFE19NAT/IT/000851

URGENT MEASURES IN THE EASTERN MEDITERRANEAN FOR THE LONG TERM CONSERVATION OF ENDANGERED POPULATION OF EUROPEAN EEL (ANGUILLA ANGUILLA)



ACTION A3: DESIGN OF EEL SPECIFIC FISH PASSES TO REOPEN OVER 1,000 KM OF HABITAT FOR UPSTREAM MIGRATION OF ELVERS

	UNITS	NUMBER	LENGTH	WIDTH	HEIGH/WEIGHT	QUANTITY	UNIT COST	TOTAL COST
RELEASE CHANNEL AND WATER SUPPLY PUMP								5'466.25 €
Stainless steel submersible pump (Head: 4-13 m, Flow: 2-5 l/s, single phase, Power 1.1 kW) (<i>Suggest product Lowara Diwa 11</i>)	unit	1				1.00	1'350.00 €	1'350.00 €
HDPE Pipe, NP 10 bar, External diameter 75 mm - pump outflow	m		12.00			12.00	18.00 €	216.00 €
HDPE Pipe, NP 10 bar, External diameter 63 mm - downstream water call	m		52.00			52.00	10.00 €	520.00 €
Electrical cable 2 x 2.5 mm	m		10.00			10.00	3.50 €	35.00 €
Protection pipe and support - hot dip galvanized steel pipe (External diameter 324 mm, thickness 5 mm)	kg		2.50		39.30	98.25	7.00 €	687.75 €
Stainless steel pipe for eels release (diameter 150 mm, thickness pipe 8/10 mm)	m		15.00			15.00	40.00 €	600.00 €
Stainless steel rings for pipe fixing (diameter 75 to 150 mm)	unit		25.00			25.00	5.50 €	137.50 €
Manpower - 3 rock climber workers team (2 days): <i>Transport of materials and equipment from the road to the working site, rings fastening, pipe fastening</i>	hrs	6			8.00	48.00	32.00 €	1'536.00 €
Manpower - electrician worker (1 day)	hrs	1			8.00	8.00	24.00 €	192.00 €
Manpower - plumber worker (1 day)	hrs	1			8.00	8.00	24.00 €	192.00 €



LIFEEL - LIFE19NAT/IT/000851

URGENT MEASURES IN THE EASTERN MEDITERRANEAN FOR THE LONG TERM CONSERVATION OF ENDANGERED POPULATION OF EUROPEAN EEL (ANGUILLA ANGUILLA)



ACTION A3: DESIGN OF EEL SPECIFIC FISH PASSES TO REOPEN OVER 1,000 KM OF HABITAT FOR UPSTREAM MIGRATION OF ELVERS

	UNITS	NUMBER	LENGTH	WIDTH	HEIGH/WEIGHT	QUANTITY	UNIT COST	TOTAL COST
COMPLEMENTARY WORKS	UNIT							3'750.00 €
100 x 100 eel pass panel to be fixed to the fence of the monitoring cabin (printing on dibond panel and setting)	unit		1.00			1.00	150.00 €	150.00 €
160 x 80 noticeboard to be fixed to the wood bulletin board (printing on dibond panel and setting)	unit		1.00			1.00	150.00 €	150.00 €
Wood bulletin board supply and setting	unit		1.00			1.00	650.00 €	450.00 €
Electrical connection to the water treatment plant electrical system	unit		1.00			1.00	2'500.00 €	2'500.00 €
Moving the existing water level sensor	unit		1.00			1.00	650.00 €	500.00 €
SECURITY COSTS	UNIT							1'500.00 €
UNEXPECTED WORKS AND ROUNDING	UNIT							1'603.84 €
TOTAL EXPENSE FOR WORKS (WITHOUT VAT)								68'548.39 €
VAT ON WORKS (24%)								16'451.61 €
TOTAL COST								85'000.00 €

NOTES:

1. THE PRICES RELATED THE STEEL PARTS SUPPLY INCLUDE THE MATERIALS (SCREWS, BOLT ANCHORS, CHEMICAL FIXING, SILICONE,) AND THE EQUIPMENT (DRILL, TOOLS) NECESSARY TO SET AND INSTALLS THE PARTS OF THE FISH-PASS
2. THE PRICES RELATED TO ROCK CLIMBER WORKERS INCLUDE CLIMBING EQUIPMENT AND FIXE CLIMBING ANCHORS





LIFEEL - LIFE19NAT/IT/000851

URGENT MEASURES IN THE EASTERN MEDITERRANEAN FOR THE LONG TERM CONSERVATION OF ENDANGERED POPULATION OF EUROPEAN EEL (ANGUILLA ANGUILLA)



ACTION A3: DESIGN OF EEL SPECIFIC FISH PASSES TO REOPEN OVER 1,000 KM OF HABITAT FOR UPSTREAM MIGRATION OF ELVERS

4 ECONOMICAL SUMMARY

WORK COSTS	EQUIPMENT / MATERIALS	MANPOWER	TOTAL
WORKSITE SETUP	1'000.00 €	1'030.00 €	2'030.00 €
PART 1 - DOWNSTREAM CONNECTION	6'080.00 €	2'400.00 €	8'480.00 €
PART 2 - HIGH SLOPE STEEL CHANNEL ON THE CONCRETE WALL AND REST POOL	8'968.44 €	2'400.00 €	11'368.44 €
PART 3 - LOW SLOPE STEEL CHANNEL BESIDE THE CONCRETE WALL	17'688.10 €	4'800.00 €	22'488.10 €
PART 4 - MONITORING CABIN CONNECTION	1'947.46 €	600.00 €	2'547.46 €
MONITORING CABIN AND CAPTURE POOL	6'242.30 €	3'072.00 €	9'314.30 €
RELEASE CHANNEL AND WATER SUPPLY PUMP	3'546.25 €	1'920.00 €	5'466.25 €
COMPLEMENTARY WORKS	1'950.00 €	1'800.00 €	3'750.00 €
SECURITY COSTS	1'000.00 €	500.00 €	1'500.00 €
UNEXPECTED WORKS AND ROUNDING	801.92 €	801.92 €	1'603.84 €
TOTAL EXPENSE FOR WORKS (WITHOUT VAT)	49'224.47 €	19'323.92 €	68'548.39 €
VAT ON WORKS (24%)			16'451.61 €
TOTAL EXPENSE, INCLUDED VAT			85'000.00 €

Varano Borghi, April 2022

Ing. Massimo Sartorelli

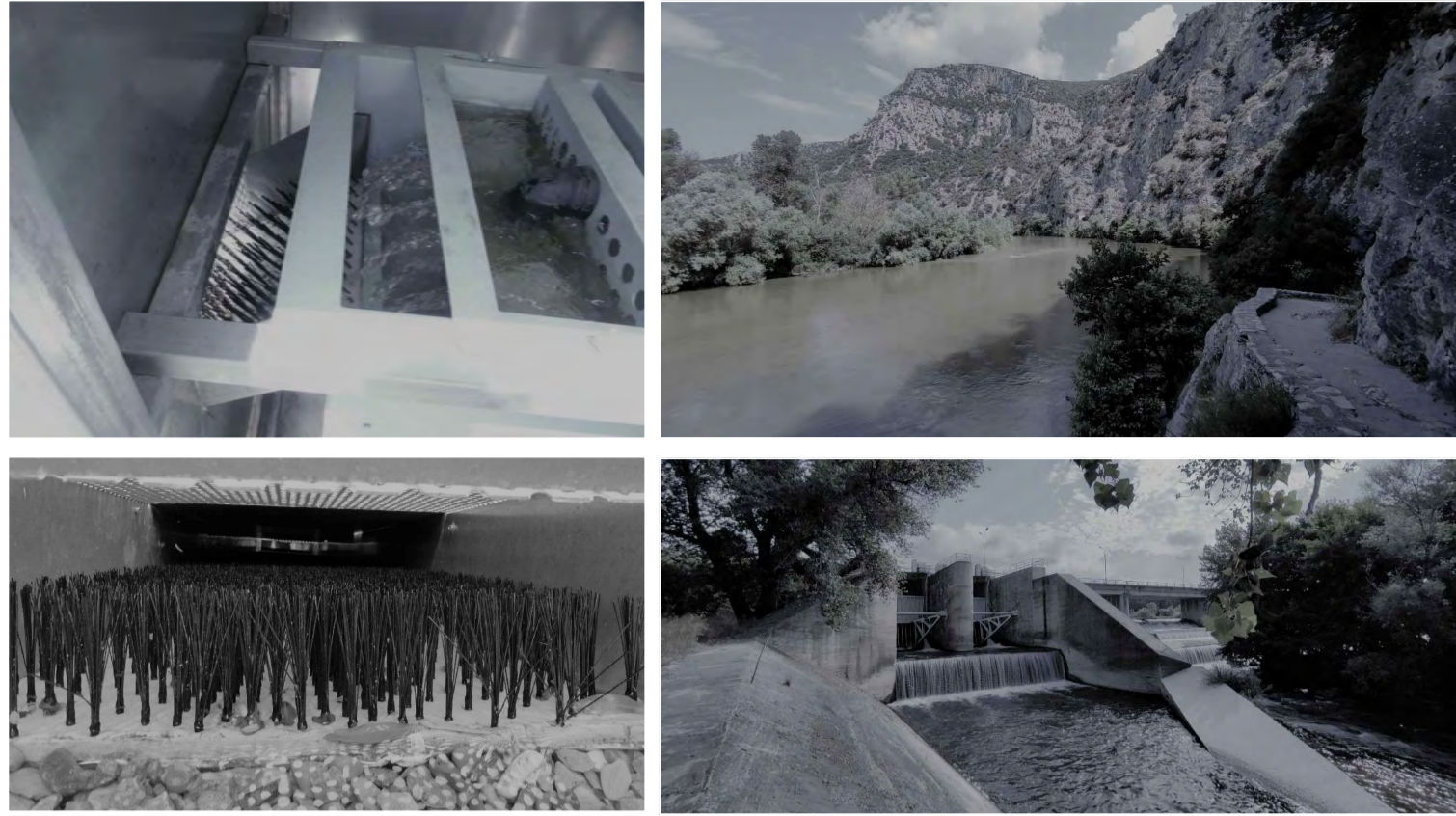



ACTION A3 Design of eel specific fish passes to reopen over 1,000 km of habitat for upstream migration of elvers

EEL PASS ON NESTOS RIVER AT TOXOTES DAM

Revision date:	Revision index:	Version:
April 2022	00	Technical specifications

Title of the document:
General Plan and profile

Ns. Rif.	Date	Scala	Paper size	Document n°
20S30	April 2022	1:5.000 - 1:250	A2	Annex 1
TECHNICAL DIRECTOR: Ing. Massimo Sartorelli		PARTNER FOR TOXOTES DAM DESIGN:		
DESIGNER: Ing. Beniamino Barengi				
		Address: Via Repubblica 1 - 21020 - Varano Borghi (VA) Tel: +39 0332.961097 Mail to: info@graila.eu - graila@pec.it		
Other authors	Verified by Dott. Ing. Massimo Sartorelli	Approved by Dott. Ing. Massimo Sartorelli		



EEL PASS: project plan - Scale 1 : 250

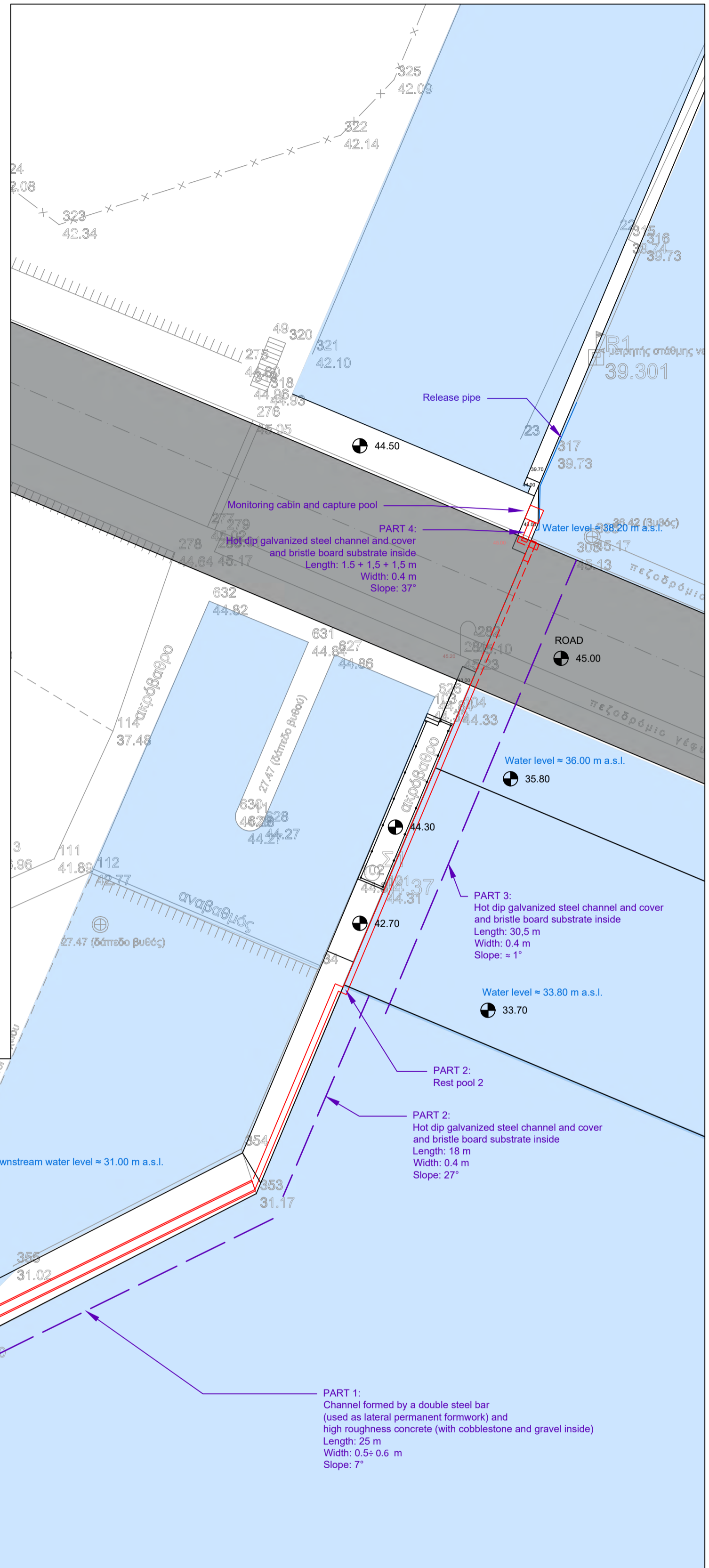

GENERAL PLAN - Scale 1 : 5.000

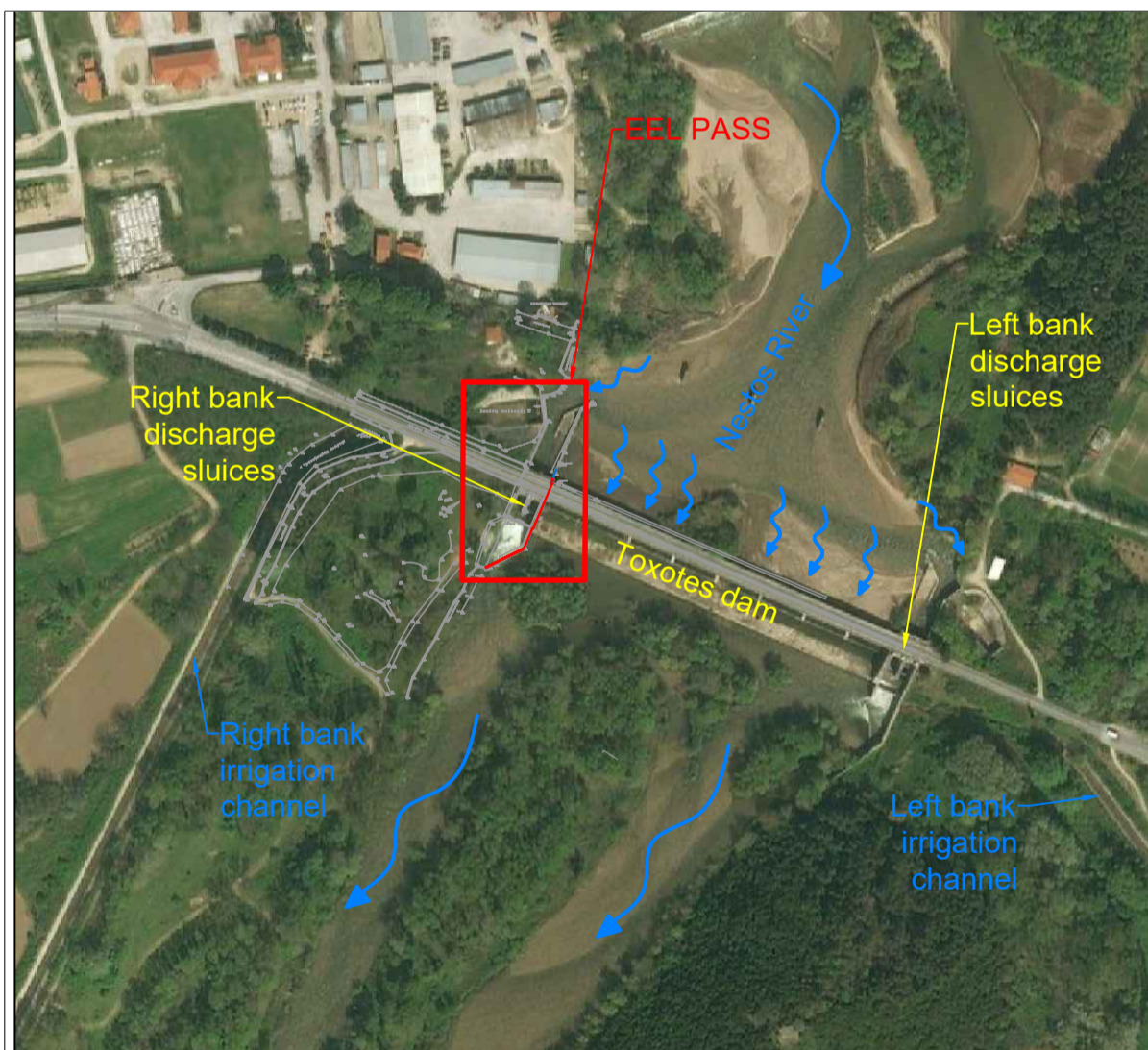

EEL PASS: project profile - Scale 1 : 250

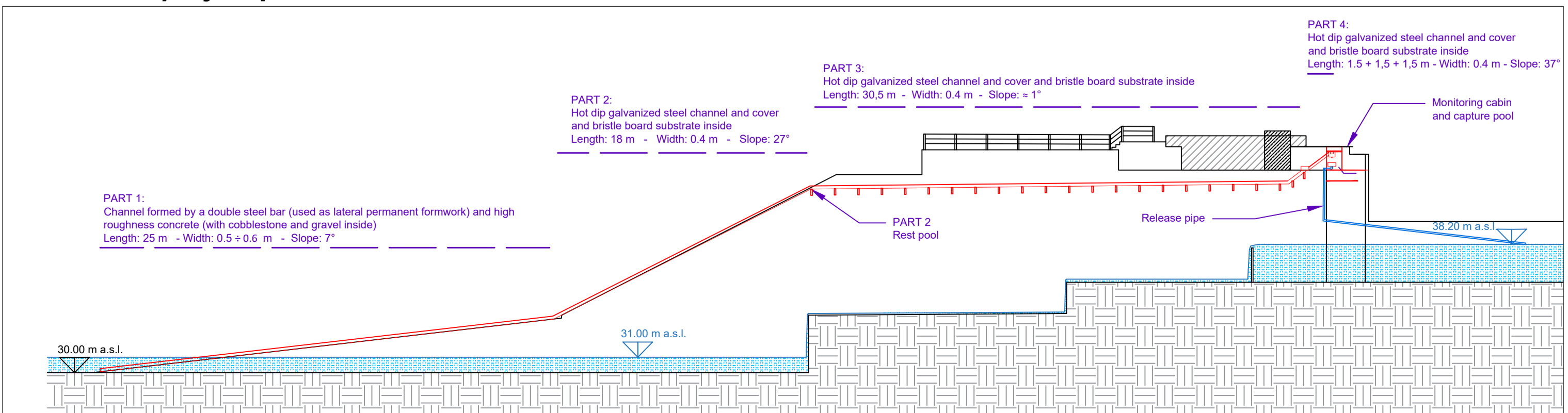

PART 1

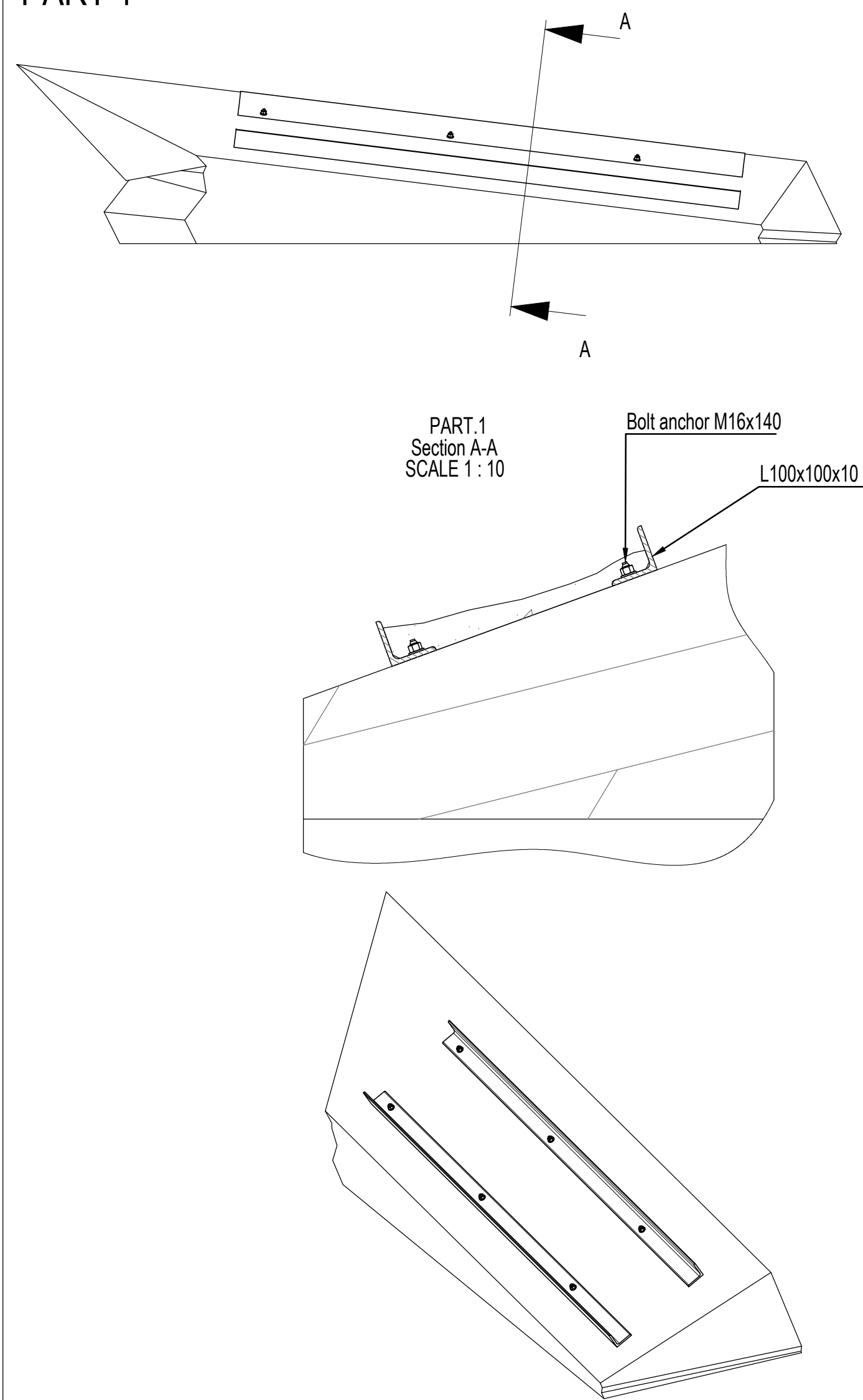

PART 2 & PART 3 - Channel features

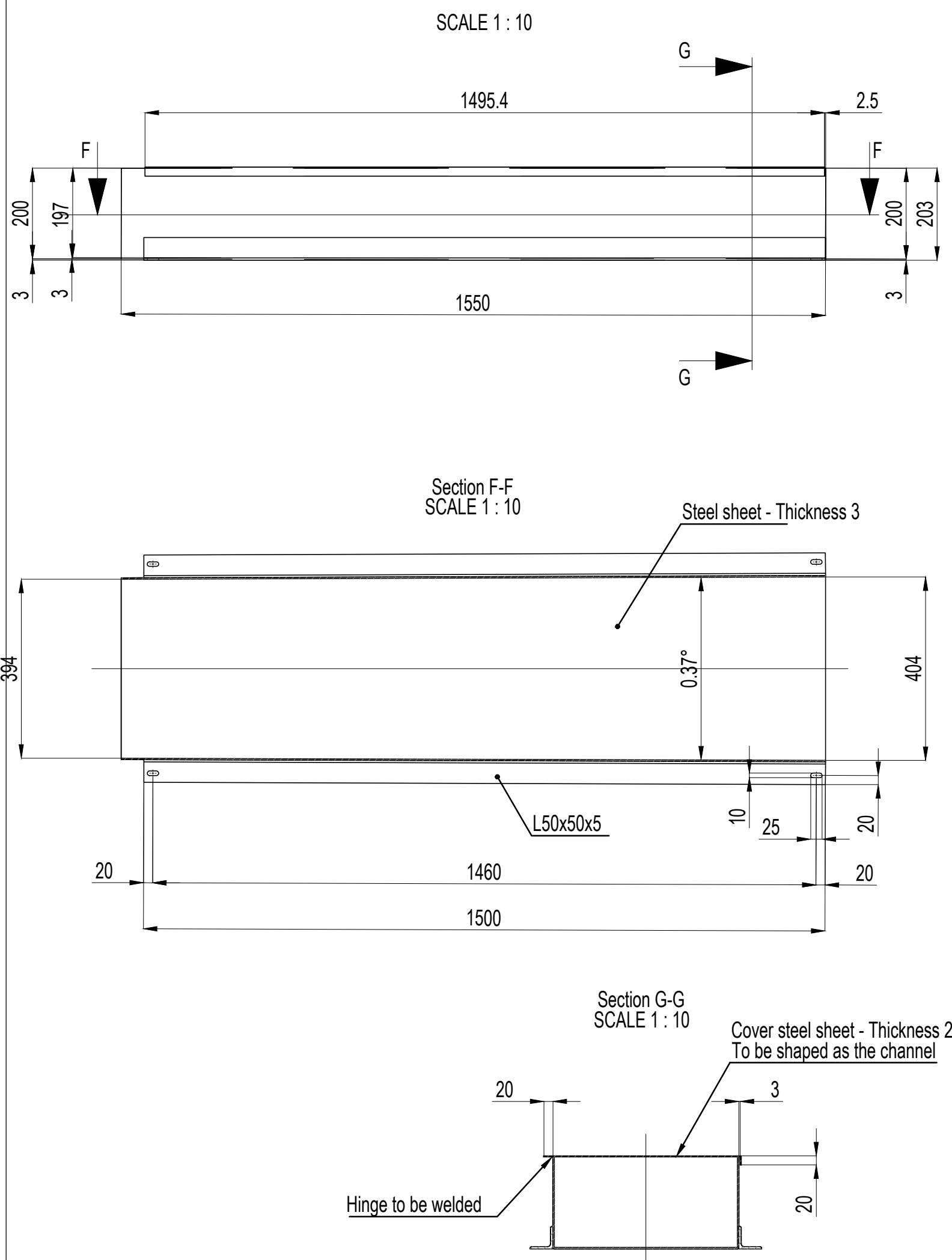

PART 2 & PART 3 - Plan & front view

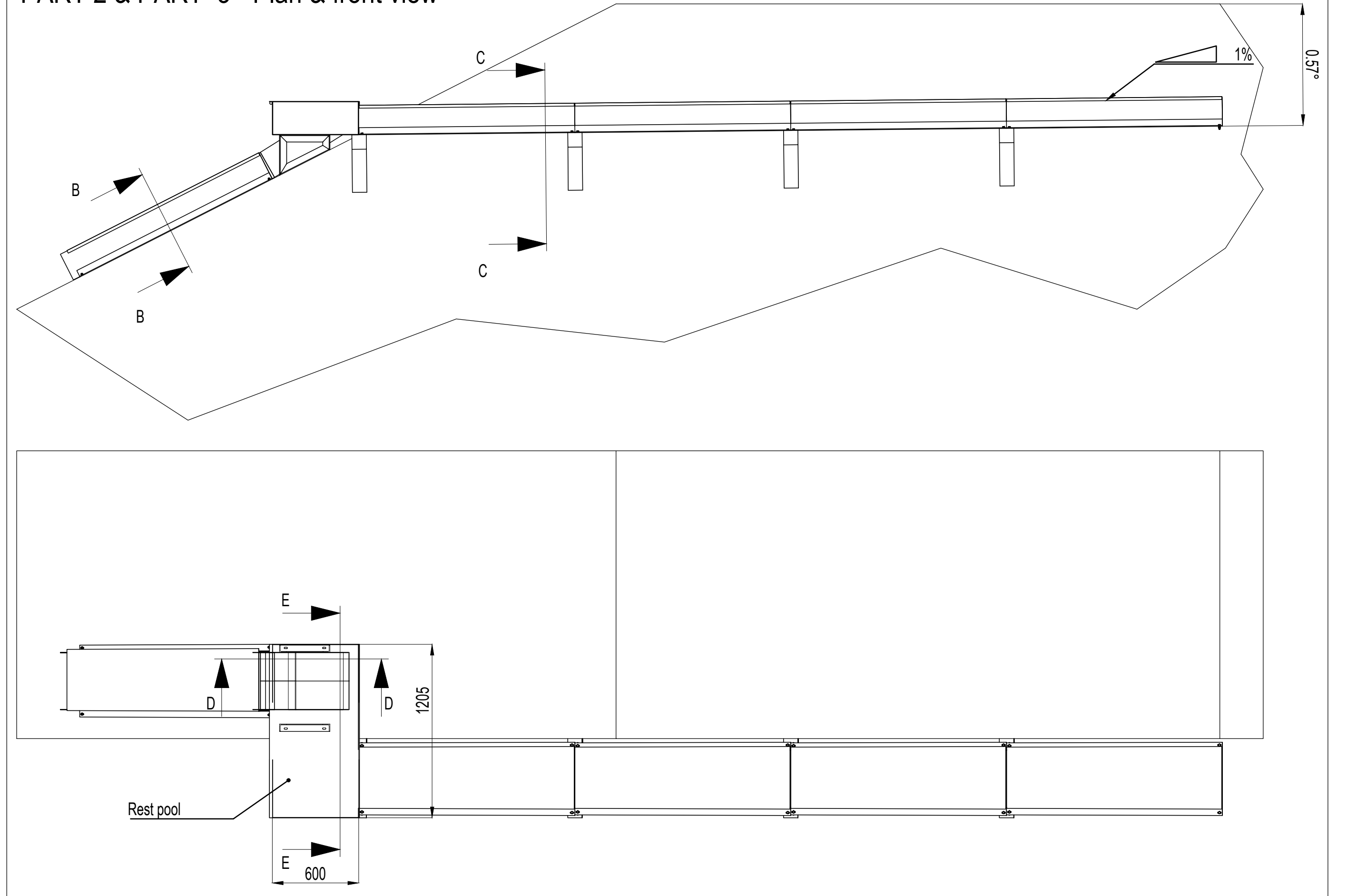

PART 2 & PART 3 - Axonometry

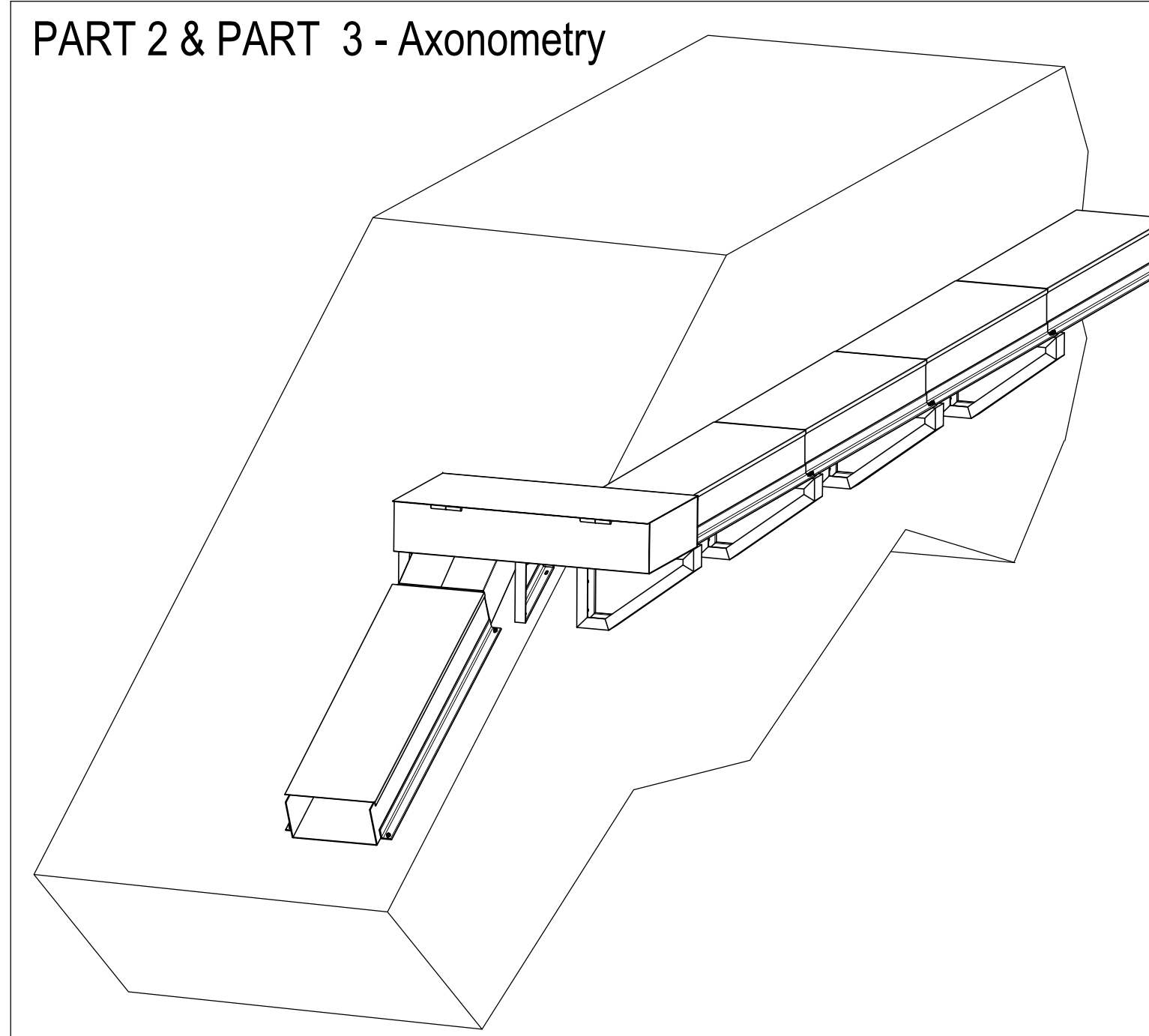

PART 2 - Channel fixing

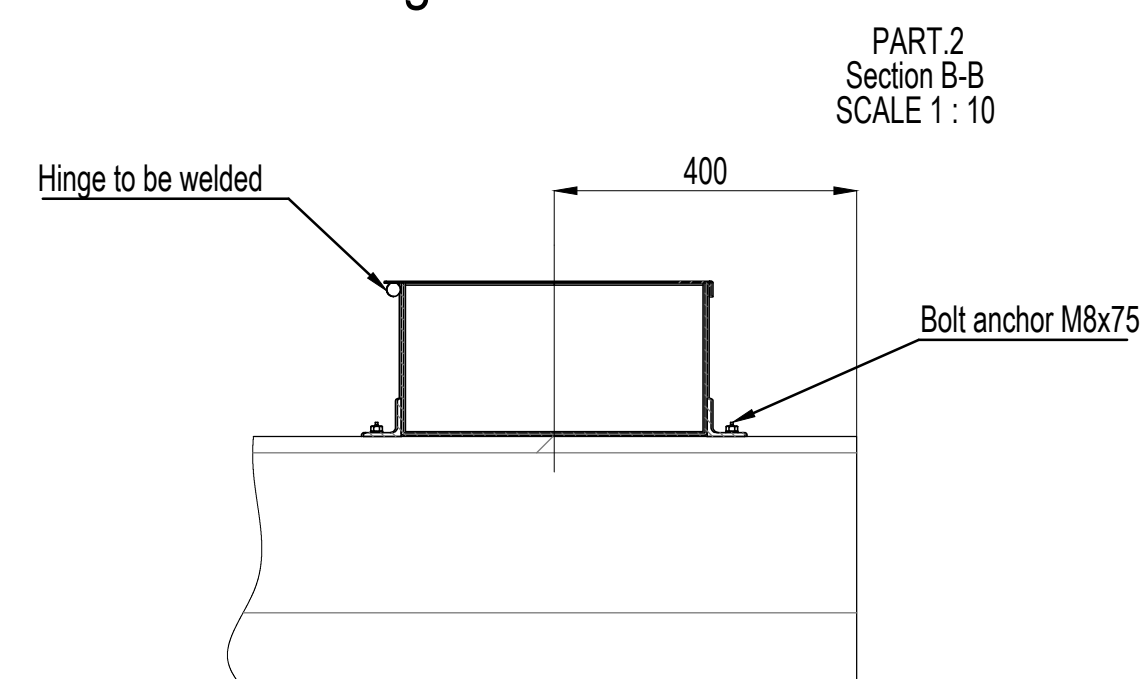

PART 2 - Rest pool features (SP1)

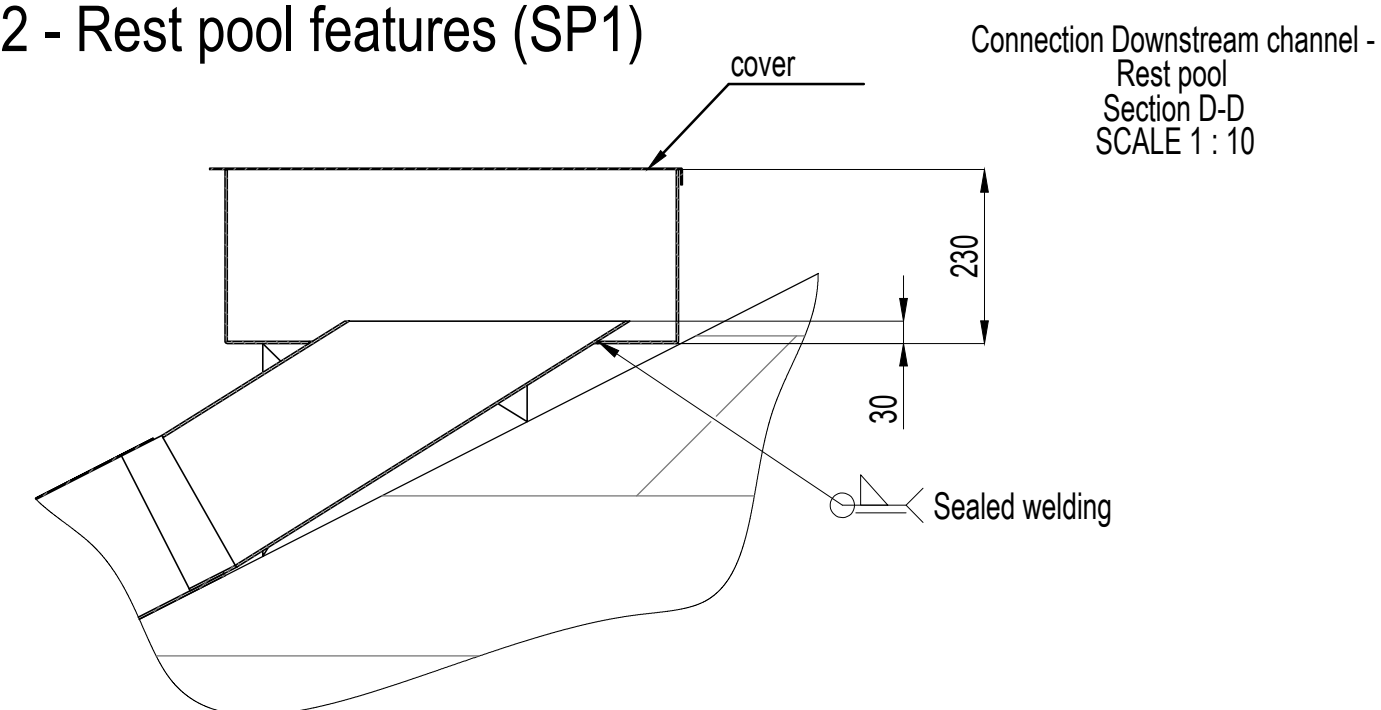

PART 3 - Brackets fixing

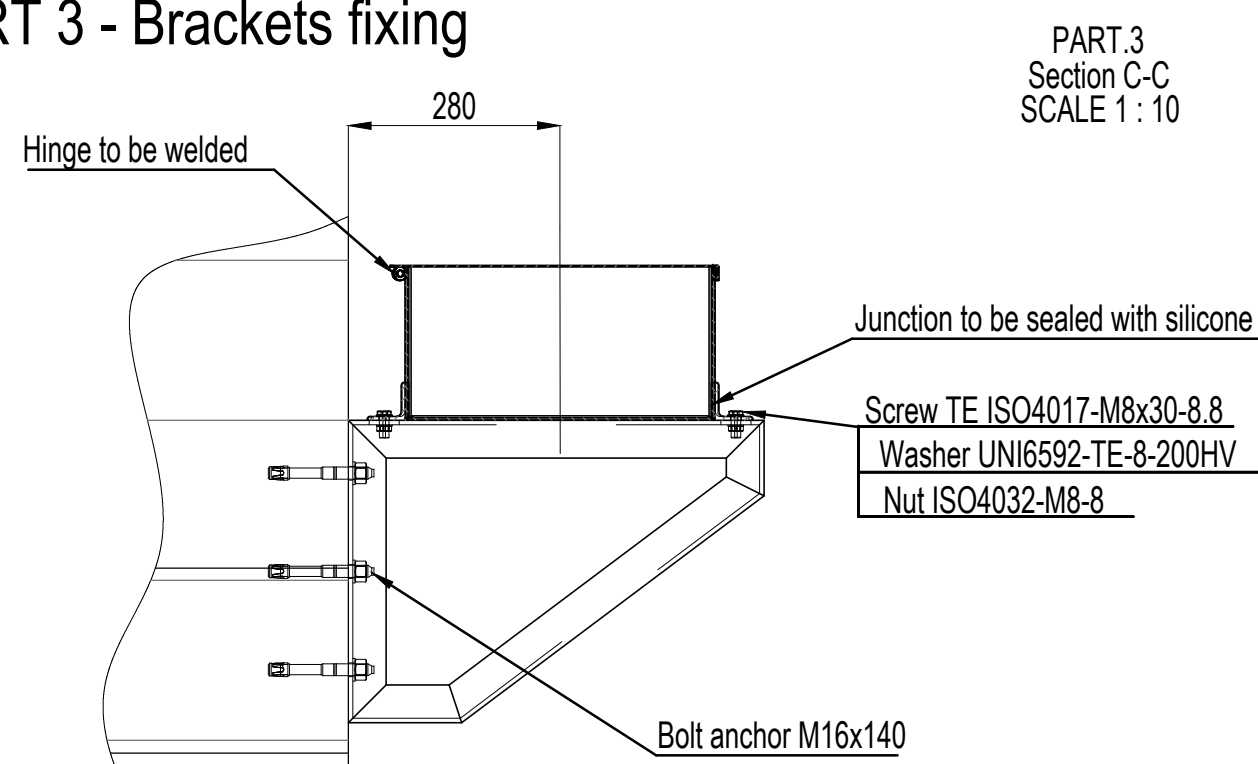

Connection upstream channel - Rest pool

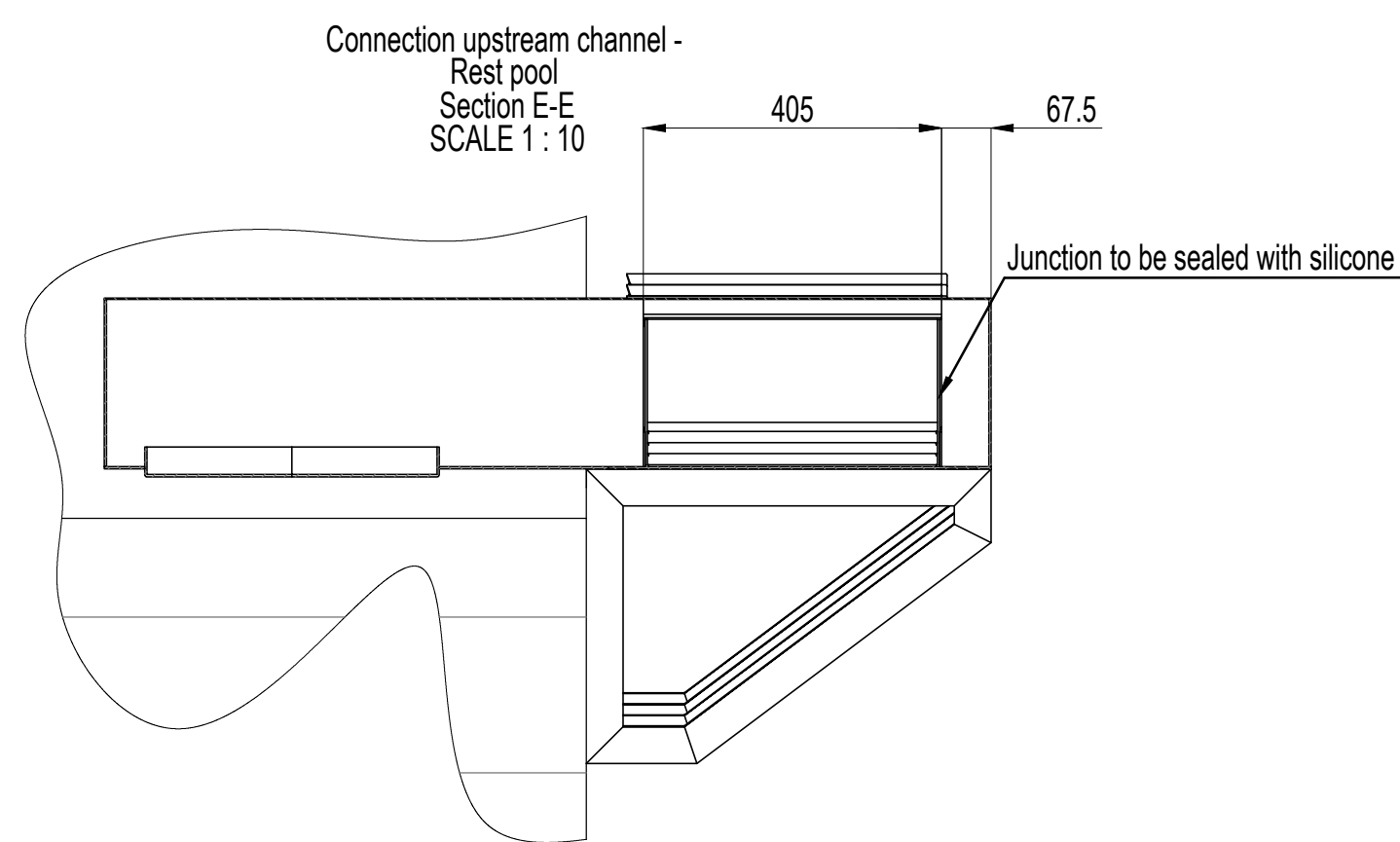

PART 3 - Brackets features

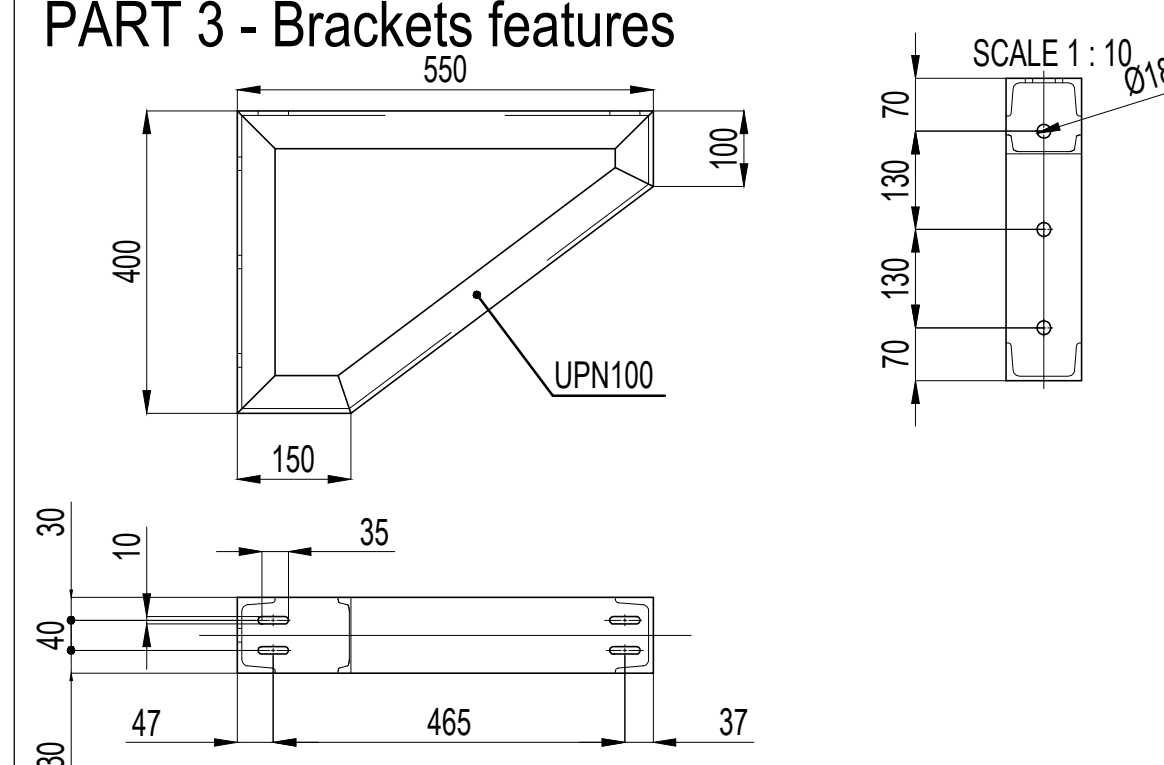

LIFEEL
LIFE19 NAT/IT/000851
Urgent measures in the Eastern Mediterranean for the long term conservation of endangered population of European eel (*Anguilla anguilla*)



ACTION A3 Design of eel specific fish passes to reopen over 1,000 km of habitat for upstream migration of eelers

EEL PASS ON NESTOS RIVER AT TOXOTES DAM

Revision date: April 2022	Revision index: 00	Version: Technical specifications
Title of the document: Technical design - Parts 1, 2, 3		
Ns. Rif. 20S30	Date April 2022	Scale 1:25 - 1:10
TECHNICAL DIRECTOR: Ing. Massimo Sartorelli		PAPER SIZE A1
DESIGNER: Ing. Beniamino Barenghi		PARTNER FOR TOXOTES DAM DESIGN: HELLENIC MINISTRY OF RURAL DEVELOPMENT & FOOD HELLENIC AGRICULTURAL ORGANISATION "DEMETER"
Other authors		Address: Via Repubblica 1 - 21020 - Varano Borghi (VA) Tel: +39 0332 961097 Mail to: info@grala.eu - grala@pec.it
Verified by: Dott. Ing. Massimo Sartorelli		Document n° Annex 2
Approved by: Dott. Ing. Massimo Sartorelli		Signature: Dott. Ing. MASSIMO SARTORELLI n° 2098 VARESE - P.I. 01501010117



PART 4 & MONITORING CABIN - Plan

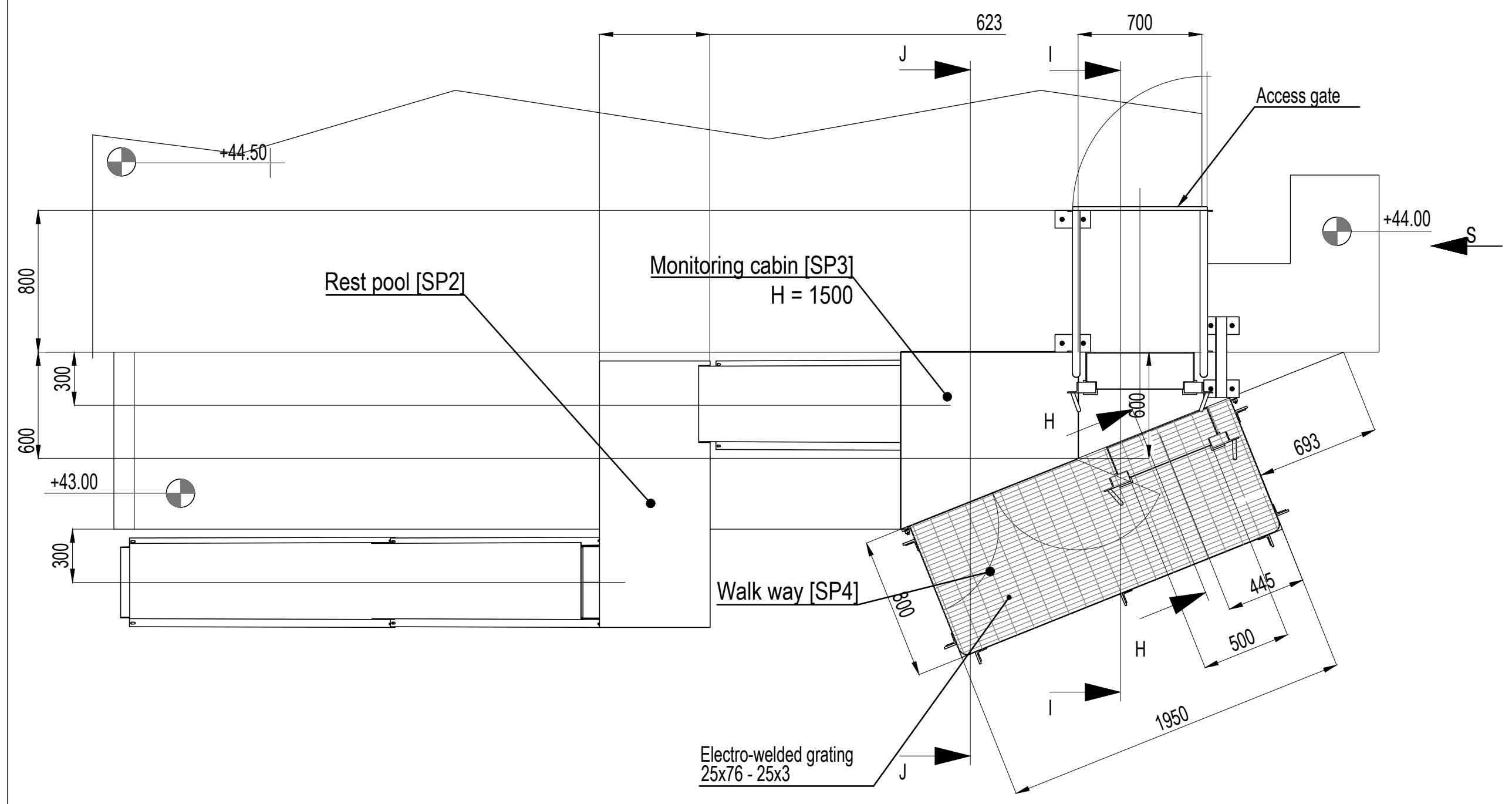

PART 4 & MONITORING CABIN - Plan

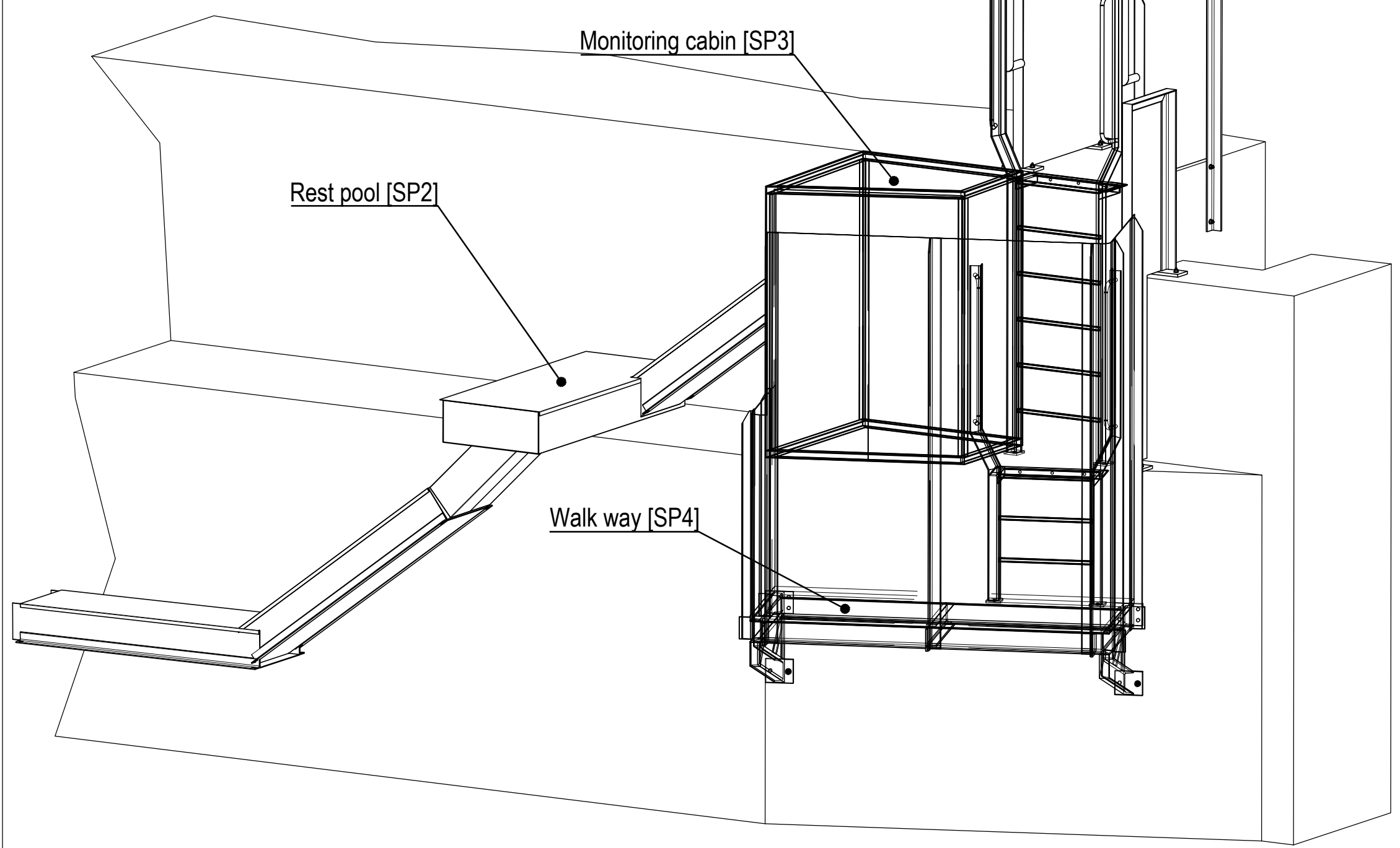

MONITORING CABIN - Equipment SCALE 1:10

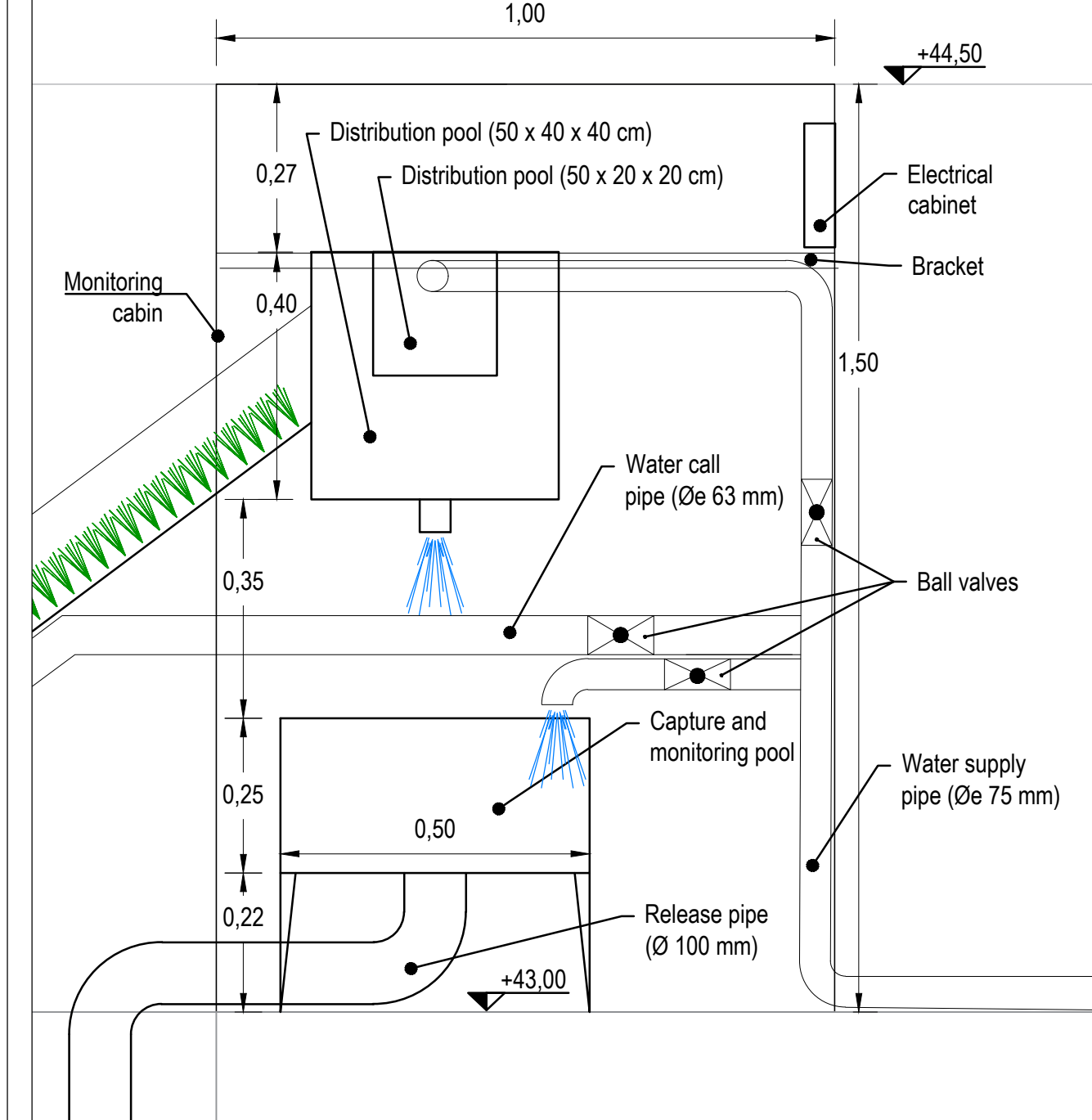

PART 4 & MONITORING CABIN

Front view

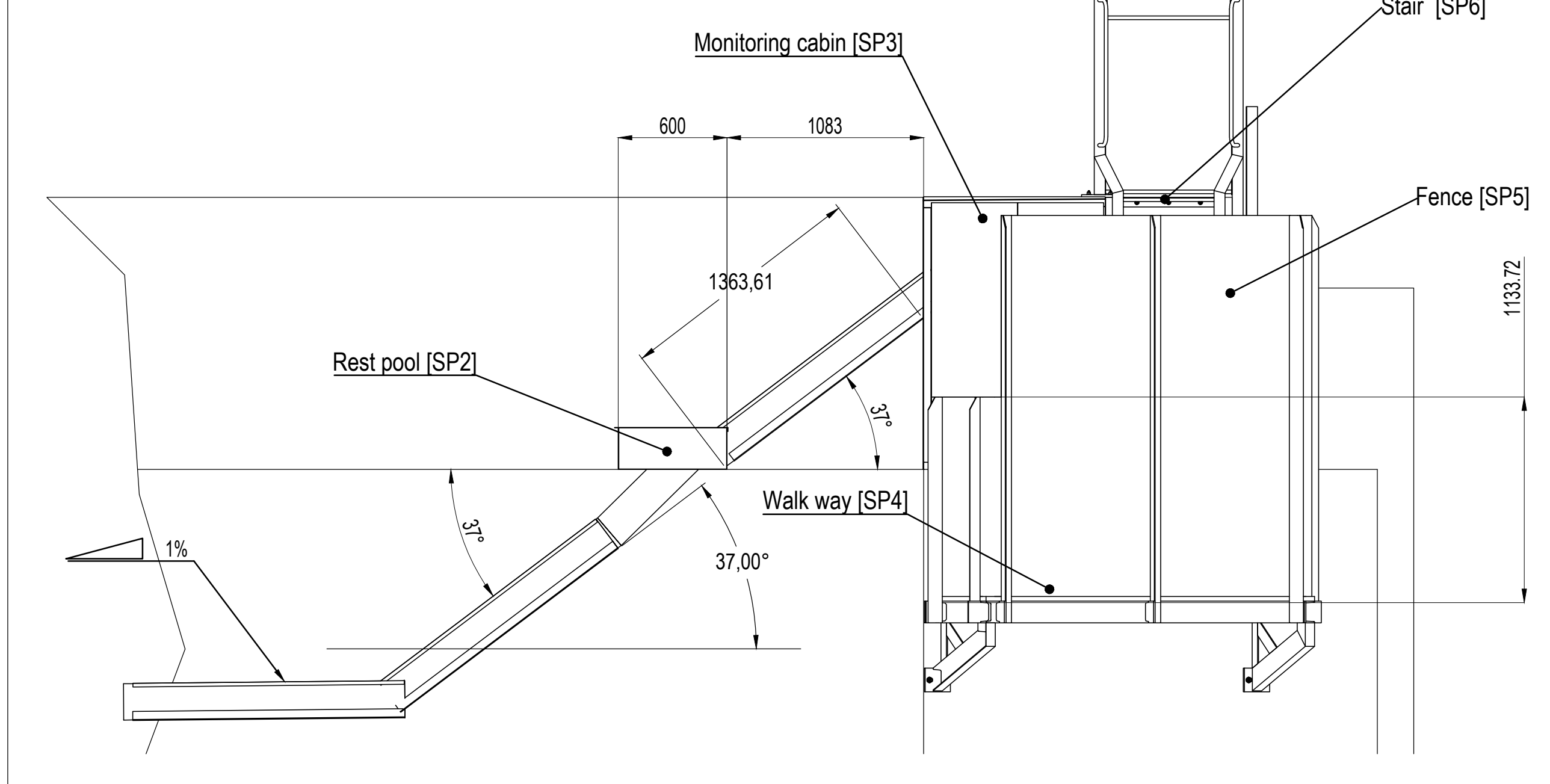

PART 4 & MONITORING CABIN

Lateral view

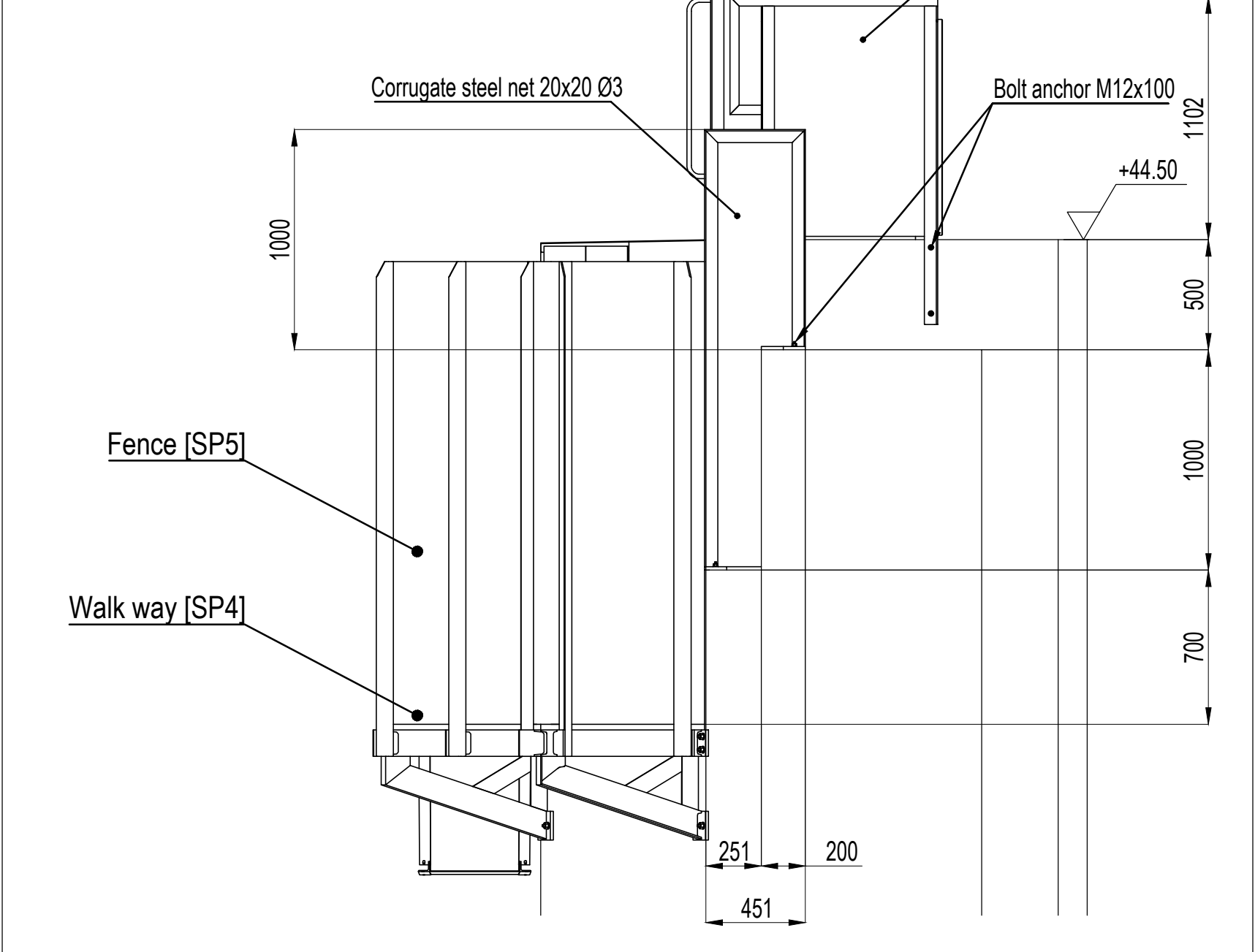

MONITORING CABIN

Cross sections

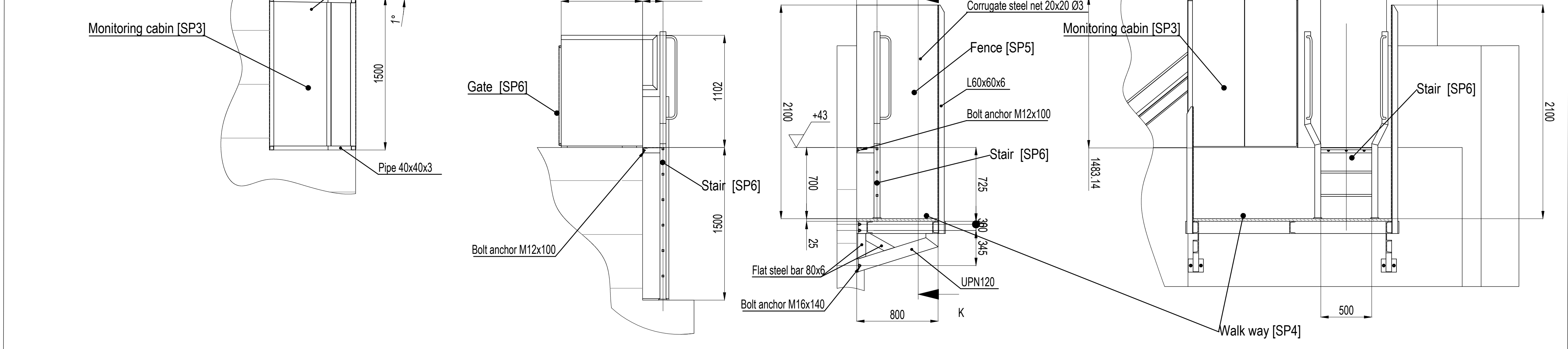

LIFEEL
LIFE19 NAT/IT/000851
Urgent measures in the Eastern Mediterranean for the long term conservation of endangered population of European eel (*Anguilla anguilla*)
NATURA 2000

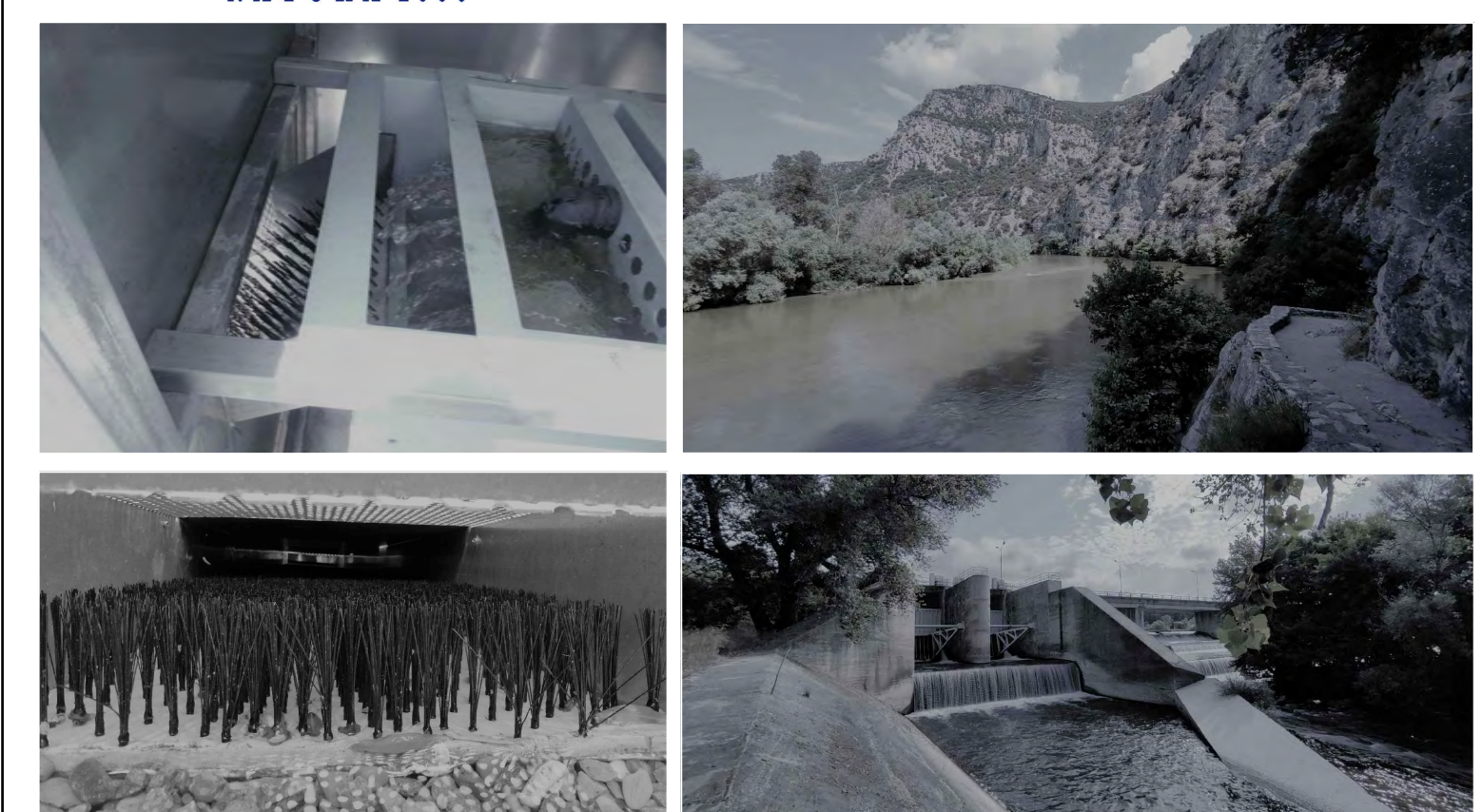

ACTION A3 Design of eel specific fish passes to reopen over 1,000 km of habitat for upstream migration of elvers

EEL PASS ON NESTOS RIVER AT TOXOTES DAM

Revision date: April 2022	Revision index: 00	Version: Technical specifications
------------------------------	-----------------------	--------------------------------------

Title of the document:
Technical design - Parts 4 and monitoring cabin

Ns. Rif. 20S30	Date April 2022	Scale 1:25 - 1:10	Paper size A1	Document n° Annex 3
-------------------	--------------------	----------------------	------------------	-------------------------------

TECHNICAL DIRECTOR:
Ing. Massimo Sartorelli

DESIGNER:
Ing. Beniamino Barengli

PARTNER FOR TOXOTES DAM DESIGN:
HELLENIC MINISTRY OF RURAL DEVELOPMENT & FOOD
HELLENIC AGRICULTURAL ORGANISATION "DEMETER"

Address: Via Repubblica 1 - 21020 - Varano Borghi (VA)
Tel: +39 0332 961097
Mail to: info@grala.eu - grala@pec.it

GRAIA

Other authors: Verified by: Dott. Ing. Massimo Sartorelli

Approved by: *Massimo Sartorelli*
Dott. Ing. Massimo Sartorelli